

SAFEONE DN3PD2

Original operating instruction

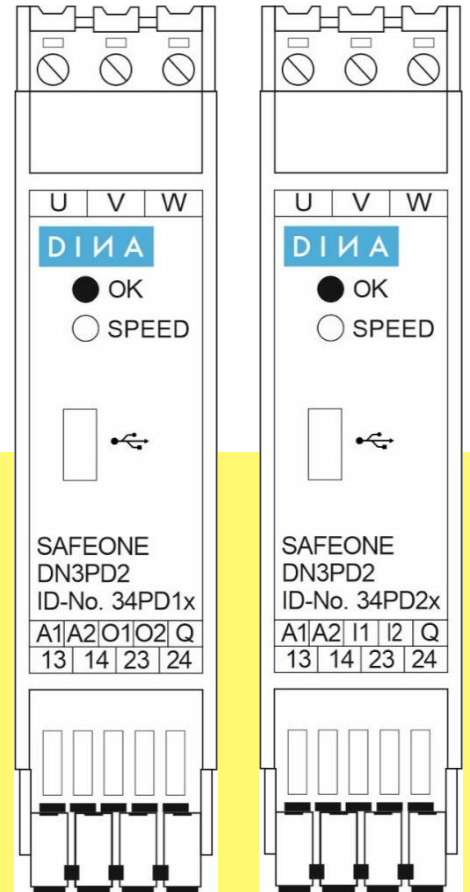

Safety switching device to monitor the speed
of three-phase and single-phase motors without sensor

DINA Elektronik GmbH

Esslinger Straße 84
72649 Wolfschlugen
Deutschland

Phone +49 7022 9517 0

Mail info@dina.de

Web www.dina.de

© Copyright by DINA Elektronik GmbH 2024

All parts of this documentation are protected by copyright.

Any use beyond that permitted under copyright law is not permitted without express written consent from the publisher. This applies in particular to the reproduction, distribution and translation of this documentation or parts thereof, as well as the storage and processing of this content using electronic data processing systems.

The information contained in this documentation corresponds to the technical state of the product at the time these operating instructions were published.

This manual is valid for:

Description	ID-No.
DN3PD2	34PD10
	34PD11
	34PD14
	34PD20
	34PD21
	34PD24

Legal information

Handbook:	Original instruction manual
Target group:	Electricians, electrical designers
Editor:	DINA Elektronik GmbH
File name:	DN3PD2-Originalbetriebsanleitung_en_202404.docx
Language:	ENG
Publication as at:	20. August 2024

Content

1	Structure of the document	1
1.1	Conventions.....	1
1.1.1	Emphasizing information	1
1.1.2	Emphasizing paragraphs using typography	1
1.1.3	Emphasizing words using typography	1
1.2	Your opinion is important to us!.....	2
2	Safety.....	3
2.1	Warnings	3
2.1.1	Function of warnings	3
2.1.2	Design of warnings.....	3
2.1.3	Hazard symbols.....	4
2.2	Qualification of personnel	4
2.2.1	Electrician.....	4
2.2.2	Electrical designers	4
2.3	Intended use and improper use	5
2.3.1	Certification data	5
2.4	Documentation	6
2.5	Safety regulations.....	6
2.5.1	Retrofitting and conversion.....	7
2.5.2	Basic safety regulations.....	7
2.6	Working on live parts	8
3	EC declaration of conformity	9
4	Product description.....	10
4.1	Product features	10
4.2	Structure.....	11
4.2.1	Pin assignment.....	11
4.2.2	Block diagrams.....	11
4.3	Input and Outputs	12
4.3.2	Acknowledgment input Q.....	12
4.3.3	Digital inputs I1 and I2.....	12
4.3.4	Enabling current path 13/14, 23/24.....	12
4.3.5	Signal outputs	12

4.3.6	USB port	13
4.3.7	LED-display	13
5	Function description	13
5.1	Speed monitoring	13
5.1.1	Acknowledge function	14
5.1.2	Minimum frequency f_{min}	14
5.1.3	Maximum frequency f_{max}	14
5.1.4	Muting/ switching of operating mode	15
5.1.5	Maximum frequency operating mode 1 f_{max1}	15
5.1.6	Maximum frequency operating mode 2 f_{max2}	15
5.1.7	Start-up monitoring.....	16
5.1.8	Functional diagram with start-up monitoring	16
5.1.9	Functional diagram without start-up monitoring	17
5.2	Switch-off delay	17
5.2.1	Frequency limit during the switch-off delay	17
5.3	Switch-on delay	17
5.4	Advanced settings	18
5.4.1	Measurement frequency.....	18
5.4.2	Sensitivity.....	19
5.4.3	Frequency comparison threshold	19
5.4.4	Coastdown monitoring.....	19
5.4.5	Phase monitoring	21
5.4.6	Sensitivity Extended wire break detection.....	21
5.5	Minimum switch-off time	21
5.6	Password.....	21
5.7	Validation.....	22
5.8	Diagnosis.....	22
5.9	Display.....	22
5.10	Error messages and LED error codes.....	23
5.11	Remedy in the event of an error.....	23
6	Applications	26
7	Configuration and startup.....	27
7.1	System requirements.....	27
7.2	Installation of the Configurations-Software.....	27

7.3	Connection to the PC.....	27
7.4	Start screen	28
7.5	User interface	29
7.6	Create a project	30
7.7	Parameterization	30
7.8	Machine data	31
7.9	Edit and Change password.....	31
7.10	Read out the project	32
7.11	Diagnosis.....	32
	7.11.1 Latch data	33
	7.11.2 System data	34
	7.11.3 Validation	35
8	Example of application.....	37
9	Order information	38
10	Technical data.....	38
10.1	Supply	38
10.2	Digital inputs	38
10.3	Measuring inputs	39
10.4	Signal outputs.....	39
10.5	Contact outputs	39
10.6	General data.....	40
10.7	Connection data	41
10.8	Environmental conditions.....	41
10.9	Dimensions.....	41
10.10	Safety technical data	41
10.11	Safety-related parameters in accordance with DIN EN ISO 13849-1:2023	42
10.12	Safety-related parameters in accordance with EN ISO 61508-High Demand.....	42
11	Installation and removal.....	43
11.1	Installing a module.....	43
	11.1.1 Overview	43
11.2	Removing a module.....	43

1 Structure of the document

1.1 Conventions

Information of particular important is emphasized in this documentation through the use of symbols, typography or formulations.

1.1.1 Emphasizing information

The following symbols indicate important information:



Degree of hazard (e.g. WARNING): Triangular symbols indicate the degree of hazard in warnings.



Type of hazard (e.g. electrical shock – dangerous voltage): Triangular symbols indicate the type of hazard in warnings.



Information: Additional clarification.



Tip: Additional information to help optimize the workflow.

1.1.2 Emphasizing paragraphs using typography

The following typography is used to emphasize paragraphs with special functions:



Indicates an instruction.



Indicates an expected reaction.



Indicates an unexpected reaction.



Indicates an item in a list.

1.1.3 Emphasizing words using typography

The following typography is used to emphasize words with special functions:

(1)

Represents a numbered item in a figure.

→

Indicates a cross-reference to another page, figure or document.

1.2 Your opinion is important to us!

We do all we can to provide complete, accurate documentation for the product. If you have any suggestions for improvement or advice for us, please share your thoughts with us. Send us your comments by e-mail to the following address.

E-mail: info@dina.de

2 Safety

2.1 Warnings

2.1.1 Function of warnings

Warnings warn users about hazards when handling the product. The hazards are classified, specified, described and supplemented with information about how to avoid them.

- If there is a warning before a list of instructions, the hazard is present throughout the entire activity.
- If there is a warning immediately before an instruction, the hazard is present during the next step.

2.1.2 Design of warnings

All warnings are indicated by a signal word and a warning symbol. The different combinations of the signal word and warning symbol indicate the degree of danger.



DANGER

For an immediate hazard that will result in severe injuries or death.



WARNING

For an immediate hazard that could result in severe injuries or death.



CAUTION

For a potentially hazardous situation that could result in injuries.



CAUTION

For a potentially harmful situation in which the product or an item near it could be damaged.



CAUTION

For a hazard that could cause environmental damage.

2.1.3 Hazard symbols

**Note**

The warning symbol may be present alongside another hazard symbol that represents the type of hazard, in order to attract the reader's attention.

Hazard symbols are indicated by a triangular symbol in the context of warnings. The following hazard symbols are used in this documentation:



Electric shock – dangerous voltage!

2.2 Qualification of personnel

DINA Elektronik GmbH distinguishes between specialist staff with different qualifications when it comes to carrying out work on the product. The minimum required qualifications are specified for each task and are defined as follows:

2.2.1 Electrician

Specialist who installs, maintains and repairs the electrical system in the product. A specialist is a person whose specialist training means that they have the knowledge and experience, including knowledge of relevant regulations, necessary to assess the work assigned to them and the potential hazards.

**Note**

When evaluating a person's specialist training, multiple years of work in the relevant field may also be taken into account.

→ **DIN VDE 1000-10** Requirements for persons working in a field of electrical engineering.

2.2.2 Electrical designers

Specialists who design the electrical system and the product. A specialist is a person whose specialist training means that they have the knowledge and experience, including knowledge of relevant regulations, necessary to assess the work assigned to them and the potential hazards.

**Note**

When evaluating a person's specialist training, multiple years of work in the relevant field may also be taken into account.

→ **DIN VDE 1000-10** Requirements for persons working in a field of electrical engineering.

2.3 Intended use and improper use

The product has exclusively been developed for use for the purpose described here. The specifications set out in these operating instructions must be strictly complied with.

- **DN3PD2** is a safety switching device to monitor the speed of three-phase and single-phase motors without sensor.
- The safety module is intended for use on machines and plants to prevent hazards from arising.

Any other form of use is regarded as improper use.

If the product is

- not used as intended,
- improperly maintained or
- incorrectly operated,

the manufacturer will not assume any liability for any damage that results. In this case, the risk shall be borne exclusively by the user.

2.3.1 Certification data

The product is certified as safety equipment in accordance with:

<ul style="list-style-type: none"> ▪ DIN EN ISO 13849-1:2023 Category 4, PLe 	
<ul style="list-style-type: none"> ▪ EC type examination certificate 	Notified body: TÜV Rheinland Industrie Service GmbH Am Grauen Stein 51105 Köln Germany NB 0035
<ul style="list-style-type: none"> ▪ EMC Directive 	Certified by: ELMAC GmbH Bondorf
<ul style="list-style-type: none"> ▪ CNL, USL 	File E227037



Note

You can download the certificates from our website:

→ <https://www.dina.de>

2.4 Documentation

Operating instructions contain instructions on how to use a product safely, correctly and cost-effectively. Follow the instructions in these operating instructions in order to prevent hazards, avoid repair costs and standstill, and improve the reliability and service life of the product. You must read the operating instructions and ensure that you understand them.



- ▶ Before working with the product, read the documentation
 - ▶ Always ensure that the operating instructions are available where the product is in use.
-

2.5 Safety regulations

The safety regulations listed below must always be complied with. In the event that these safety regulations are not complied with or the device is used improperly, **DINA Elektronik GmbH** accepts no liability for any resulting injury or damage.

- The product must only be installed and commissioned by a skilled electrician or a trained, instructed person, who is familiar with these operating instructions and the applicable specifications regarding occupational health and safety and accident prevention.
-



WARNING

Danger to persons and materials! In the event that specifications are not complied with, this can result in death, severe injuries or significant material damage.

Observe VDE, EN and local regulations, in particular with regard to protective measures.

- If the emergency stop is used, either the integrated restart prevention function must be used or the machine must be prevented from restarting automatically using a superordinate control system.
 - When installing the device, the required distances as per DIN EN 50274, VDE 0660514 must be taken into account.
 - ▶ During transport, storage and operation, comply with the conditions set out in EN 60068-2-1, 2-2.
 - ▶ Assemble the device in a control cabinet with at least IP54 degree of protection. Otherwise, dust and moisture can impair the functions. The device must be installed in a control cabinet.
 - ▶ Ensure that the output contacts have sufficient protective circuitry for capacitive and inductive loads.
 - ▶ Follow the specifications in the general technical data.
-



Note

More detailed information can be found in the → **Technical data** section.

**WARNING**

Electric shock – dangerous voltage! During operation, switching devices conduct dangerous voltages.

Never remove protective covers from electrical switching devices during operation.

- ▶ Replace the device the first time a fault occurs.
-



- ▶ Dispose of the device in accordance with nationally applicable environmental regulations.
-

2.5.1 Retrofitting and conversion

- Unauthorized conversion voids any warranty. This can cause hazards that can lead to severe or even fatal injury.

2.5.2 Basic safety regulations

The safety regulations listed below must always be complied with. In the event that these safety regulations are not complied with or the device is used improperly, **DINA Elektronik GmbH** accepts no liability for any resulting injury or damage.

- The product described here has been developed to perform safety-related functions as part of an entire system.
- The entire system is made up of sensors, analysis units, reporting units and safe switch-off concepts.
- It is the responsibility of the manufacturer of a system or machine to validate the correct overall function.
- The manufacturer of the system is obligated to check and document the efficacy of the implemented safety concept within the entire system. This documentation must be produced again every time the safety concept or safety parameters are modified.
- The manufacturer's specifications for the system or machine with regard to maintenance intervals must be complied with.
- **DINA Elektronik GmbH** is not able to make any guarantees regarding the properties of an overall system not designed by the company.
- **DINA Elektronik GmbH** accepts no liability for any recommendations given or implied in the following description.
- No new guarantee, warranty or liability claims that go beyond **DINA Elektronik GmbH's** general delivery conditions can be derived from the following description.
- To prevent EMC disturbances, the physical environmental and operating conditions where the product is installed must correspond to the EMC section of DIN EN 602041.
- If contact outputs are used, the safety function must be requested in accordance with the diagnostic test intervals of DIN EN 61800-5-2.

- When using inputs I1 and I2 (ID No. 34PD2x) and contact outputs are used, the safety function must be requested in the following diagnostic test intervals in accordance with DIN EN 61800-5-2.
 - one test per year for SIL 2, PL d/category 3;
 - one test every three months for SIL 3, PL e/Category 3;
 - one test daily for SIL 3, PL e/Category 4.

2.6 Working on live parts



WARNING



Electric shock – dangerous voltage! Touching live components can cause severe or even fatal injury, depending on circumstances, as a result of an electric shock.

- ▶ Never assume that a circuit is dead.
 - ▶ Always check circuits as a safety precaution! Components being worked on may only be live if this is absolutely necessary and stipulated.
 - ▶ Accident prevention regulations (e.g. VBG4 and VDE 105) must be observed during all work.
 - ▶ Only use suitable, intact tools and measuring equipment.
-

3 EC declaration of conformity



Original EG-Konformitätserklärung

(gemäß der Richtlinie 2006/42/EG, Anhang II, IA)

Original EC-Declaration of Conformity

(according to Directive 2006/42 / EC, Annex II, IA)

DINA Elektronik GmbH
 Esslinger Str. 84
 72649 Wolfschlugen
 Deutschland

Wir erklären, dass das folgende Produkt allen einschlägigen Bestimmungen der Richtlinie 2006/42/EG entspricht.
 We declare, that the following product fulfils all the relevant provisions of Directive 2006/42 / EC.

Produkt/Product	Funktion/Function
DN3PD2 Drehzahlwächter ohne Sensorik/ sensorless speed monitoring ID-No. 34PD..	Sensorlose Drehzahlüberwachung bei Drei- und Einphasen Motoren Sensorless motion monitoring for 3-phases and single phase motors.

Weitere EU-Richtlinien/ Further EC- directives	
2014/30/EU	EMV-Richtlinie/EMC-Directive
2011/65/EU	RoHS Richtlinie/RoHS-Directive

Benannte Stelle/Notified Body	EG Baumusterprüfbescheinigung/EC Type-Examination certificate
TÜV Rheinland Industrie Service GmbH Am Grauen Stein D-51105 Köln NB 0035	Reg.-Nr./No.: 01/205/5759.00/20

Bevollmächtigter für die Zusammenstellung der technischen Unterlagen/Authorized representative for the compilation of the technical documents.
DINA Elektronik GmbH Esslinger Str. 84 72649 Wolfschlugen Deutschland

Wolfschlugen, 26.07.2022

Markus Henzler, Entwicklung

4 Product description

The **SAFEONE DN3PD2** is a safety switching device for sensorless speed monitoring of electric drives.

4.1 Product features

- Monitoring of a minimum and maximum speed and of a speed range
- Muting function
Alternatively: Monitoring of two maximum speeds, switchable via digital inputs
- Standard Mini-USB-A-port
- Force-guided relay contacts, Acknowledgment input, signal outputs or digital inputs
- LED display for operational readiness and the switching status of the contact outputs
- Low overall width of 22.5 mm
- DIN rail mounting in the control cabinet
- Suitable up to Cat 4/PLe according to EN ISO 13849-1
- Simple parameterization, validation and online monitoring via the free downloadable GO:BEYOND® software

The module is available in the following variants:

ID-No.	Properties		
	Measuring voltage	Frequency	Inputs/outputs
34PD10	90V to 690V AC	0,5Hz to 1200Hz	2 signal outputs
34PD11	24V to 120V AC	0,5Hz to 1200Hz	2 signal outputs
34PD14	90V to 690V AC	100Hz to 1650Hz	2 signal outputs
34PD20	90V to 690V AC	0,5Hz to 1200Hz	2 inputs for operating mode switching or muting
34PD21	24V to 120V AC	0,5Hz to 1200Hz	2 inputs for operating mode switching or muting
34PD24	90V to 690V AC	100Hz to 1650Hz	2 inputs for operating mode switching or muting

4.2 Structure

4.2.1 Pin assignment

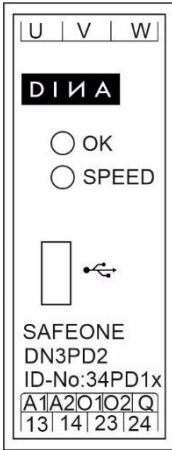
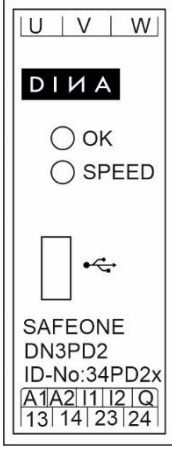
	A1	Power supply +24V DC
	A2	Power supply 0 V
	U, V, W	Measuring inputs are to be connected directly to the motor, without switching contacts between
	Q	Acknowledgment input can be parameterized, manually or automatically
	O1, O2 at 34PD1x	Digital, positive switching semiconductor outputs
	I1, I2 at 34PD2x	Digital inputs
	13/14, 23/24	Enabling contacts (2 NO-contacts)
	USB Port	Mini-USB for connection at PC
	LED OK	Operational readiness indicator
	LED SPEED	Status indicator for enabling current path
		

4.2.2 Block diagrams

34PD1x

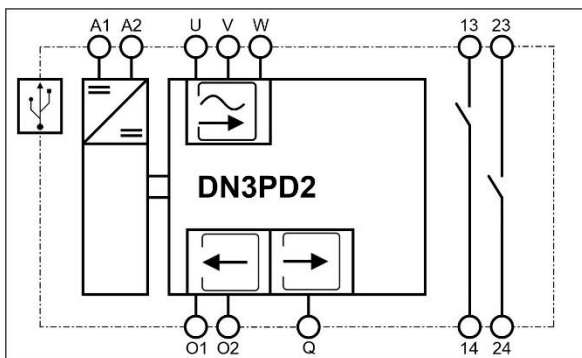

34PD2x

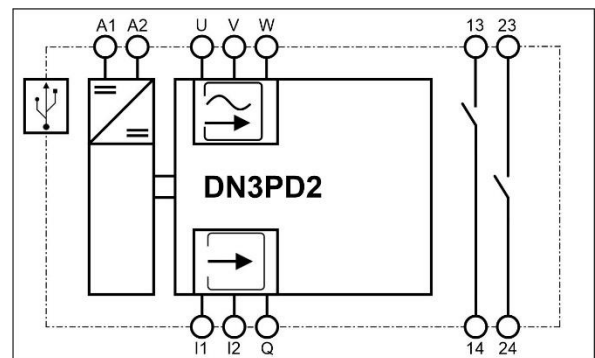

Inputs



Outputs



Measuring inputs



USB

4.3 Input and Outputs

4.3.1 24 V supply A1 and A2

Supply the safety relay module with appropriate voltage via connections A1 and A2.

Protect the power supply with a suitable external fuse.

4.3.2 Acknowledgment input Q

Depending on the wiring and parameterization of acknowledgment input Q, enabling current path offers two possible types of startup behavior for speed monitoring:

- Automatic

or

- Manual, monitored

With manual acknowledgment, the acknowledgment input can be used to delete error messages. See chapter „[Remedy in the event of an error](#)“

4.3.3 Digital inputs I1 and I2

Depending on the parameterization, the digital inputs I1 and I2 (only with ID No. 34PD2x) are used either as muting inputs to bridge frequency monitoring or to switch to a second frequency limit.

4.3.4 Enabling current path 13/14, 23/24

The enabling current path is implemented by two safety relays, each with a NO contact.

4.3.5 Signal outputs

You can use the signal outputs O1 and O2 (only with ID-No. 34PD1x) to control e.c. a non-safety PLC or signal units.

The signal outputs have the following properties:

- Digital
- PNP
- potential-bound
- short circuit and overload protection
- not safety-related

The output O1 indicates the state of the enabling current path. It switches 24 V when the enabling current path is closed. The output O2 indicates the operational readiness. This switches off in case of an error.

4.3.6 USB port

Connect the safety relay module to the PC via the micro USB port.

The PC connection is required for the following actions:

- Transferring the application parameters
- Reading out the parameters in order to open them as a project in the configuration software and edit them if necessary
- Diagnosis
- Validation

4.3.7 LED-display

The two-color LEDs “OK” and “SPEED” of the safety switching device indicate the operational readiness and the status of the enabling current path.

5 Function description

The two-channel evaluation unit of the safety switching device measures the frequency of the effective rotating field of the motor at the measuring terminals U, V, W.

In the event of an underrange or overrange of the parameterized frequencies (f_{min} and f_{max}), an internal error, or an external error, enabling current path 13/14, 23/24 opens immediately. The device is in the safe switching state.

After applying the operating voltage (24 V DC) to terminals A1 and A2, the safety switching device operate a self-test. The safety relay is in safe condition for the duration of the self-test. The LED OK lights up red.

When the operating voltage (24 V DC) is applied at terminal blocks A1 and A2, the safety switching device performs a self-test. The safety switching device is in the safe state for the duration of the self-test. The enabling current path is open.

The device is ready to operate following a successful self-test. The OK LED lights up green.

5.1 Speed monitoring

The following monitoring functions are possible:

- Monitoring only for maximum speed
- Monitoring of a speed range with start-up monitoring
- Monitoring of a speed range without start-up monitoring
- Monitoring of two speeds by switching operating modes
- Hiding the monitoring (muting)

The parameters f_{max} (maximum frequency) and f_{min} (minimum frequency) define the speed limits of the motor. The limit frequencies f_{max} and f_{min} are calculated from the speed n and the number of pole pairs:

$f \text{ [Hz]} = (n \text{ [U/min]} / 60) \times \text{number of pole pairs}$

Example: $5000 \text{ rev /min} \times 3 \text{ (number of pole pairs)} / 60 = 250\text{Hz}$

Asynchronous motors have a load-dependent slip between the motor speed and the rotating field frequency. This must be observed by the configuration of the switching threshold (f_{\min} and f_{\max}).



CAUTION

Note that the method of frequency measurement does not recognize a mechanically blocked motor or an overloaded motor!

5.1.1 Acknowledge function

The acknowledgment function allows the module to be returned to operational readiness following a shutdown due to under- or over-speed. If neither of the above states is present, the reset is performed via input Q on the module.

Automatic or manual acknowledgment is possible. In the case of automatic acknowledgment, input Q must be constantly connected to 24 V DC.

Manual monitored acknowledgment takes place on a falling edge of a 24 V signal. The acknowledgment signal is subject to time monitoring: The 24 V signal must be applied at input Q for min 200 ms and max. 5 s.

5.1.2 Minimum frequency f_{\min}

If f_{\min} is not reached, the output contacts (13-14 / 23-24) switch off.

They are switched on again following acknowledgment via acknowledgment input Q.

The conditions for switching on again differ according to the type of acknowledgment. See chapter „[Start-up monitoring](#)“

If $f_{\min} = 0$ there is no monitoring to a minimum speed. The output contacts then remain closed at standstill.

5.1.3 Maximum frequency f_{\max}

If f_{\max} is exceeded, the output contacts (13-14 / 23-24) switch off.

They are switched on again following acknowledgment via acknowledgment input Q and when f_{\max} (minus hysteresis) is undershot.



CAUTION

Please note that if f_{\min} monitoring is not parameterized, a coasting motor can be recognized as a standstill.

In this case, use the „[Coastdown monitoring](#)“ function.

5.1.4 Muting/ switching of operating mode

The inputs I1 and I2 of the modules with the ID no. 34PD2x are used as standard to hide speed monitoring (muting) or can alternatively be used to switch to a second operating mode. You make the selection during parameterizing.

Muting: To implement the muting function, proceed as follows:

- ▶ Connect a constant voltage of 24V to the inputs I1 and I2.
- ◀ The speed monitoring is hidden. The enable current path is closed as long as the frequency is within the measurable range (<1500Hz or <1800Hz).



Note

The diagnostic function for detecting wire breaks remains active.

Switching of operating mode: To implement the switching operating mode function, proceed as follows:

- ▶ Activate the function in the configuration software.
- ▶ Enter the two maximum frequencies f_{max1} and f_{max2} .
- ▶ Connect a constant voltage of 24V to the inputs I1 and I2.
- ◀ The safety switching device monitors f_{max2} .
- ▶ Open the inputs I1 and I2.
- ◀ The safety switching device monitors f_{max1} .



When using inputs I1 and I2 (ID No. 34PD2x), they must switch from high to low in accordance with the diagnostic test intervals of DIN EN 61800-5-2 in order to request the safety function. See chapter [“Basic safety regulations”](#).

5.1.5 Maximum frequency operating mode 1 f_{max1}

If f_{max1} is exceeded, the output contacts (13-14 / 23-24) switch off.

They are switched on again following acknowledgment via acknowledgment input Q and when f_{max1} (minus hysteresis) is undershot.

5.1.6 Maximum frequency operating mode 2 f_{max2}

If f_{max2} is exceeded, the output contacts (13-14 / 23-24) switch off.

They are switched on again following acknowledgment via acknowledgment input Q and when f_{max1} (minus hysteresis) is undershot.



Note

f_{max1} must be smaller than f_{max2} .

5.1.7 Start-up monitoring

The startup monitoring time t_A is a time limit within which the actual speed must be greater than f_{min} . If the minimum speed including hysteresis ($f_{min} + Hys$) is not reached within this time, the enable current path opens again.

The start-up monitoring time can be parameterized (0s to 60s). It cannot be retrigged and cannot be restarted while it is running.

The start-up monitoring time starts:

- In case of manual acknowledgment: with the falling edge of the acknowledge signal
- In case of automatic acknowledgment: if the actual speed is $> 1\text{Hz}$

In the acknowledgment mode without startup monitoring (0s), the outputs only switch on within the permitted range.

5.1.8 Functional diagram with start-up monitoring

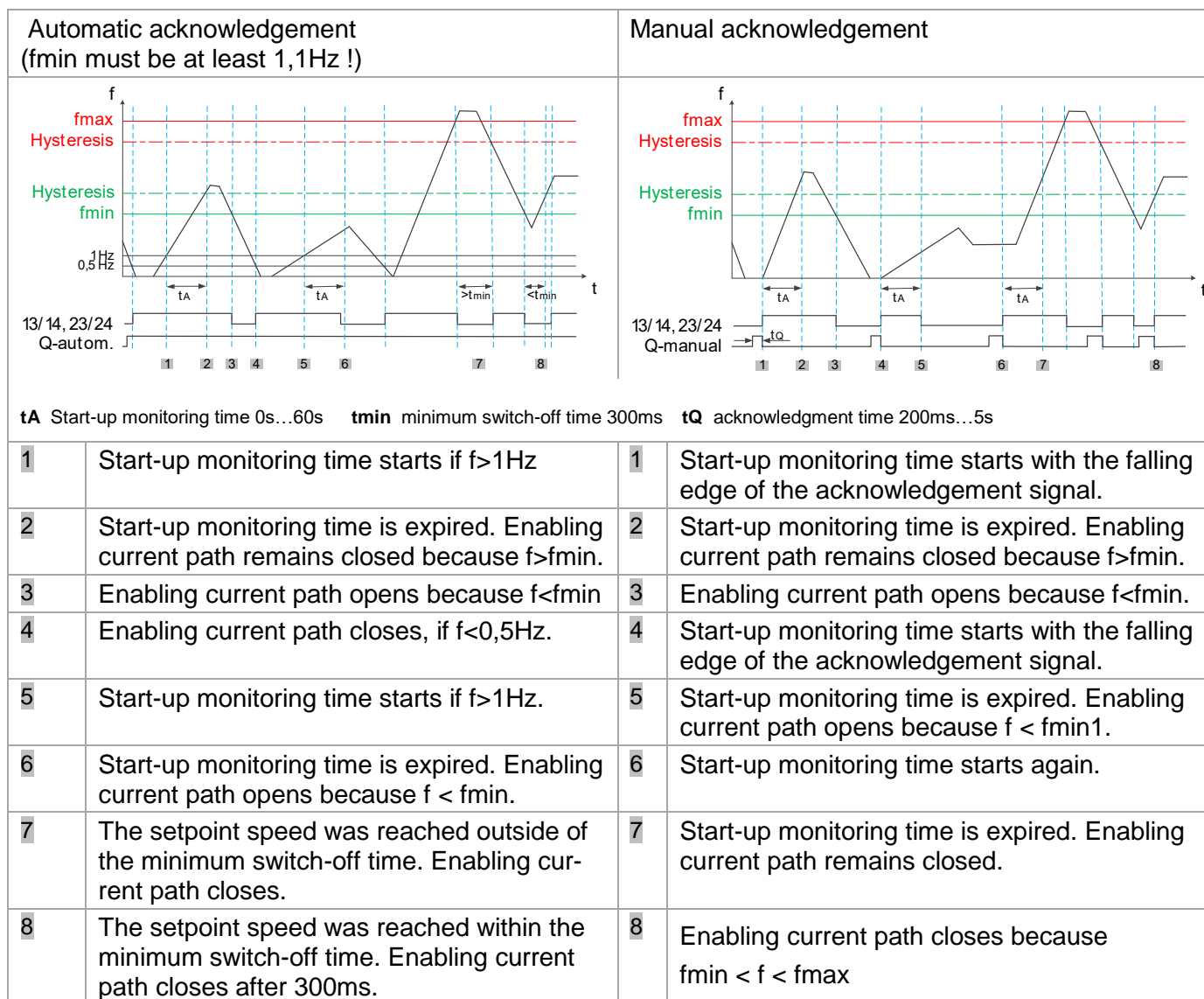

5.1.9 Functional diagram without start-up monitoring

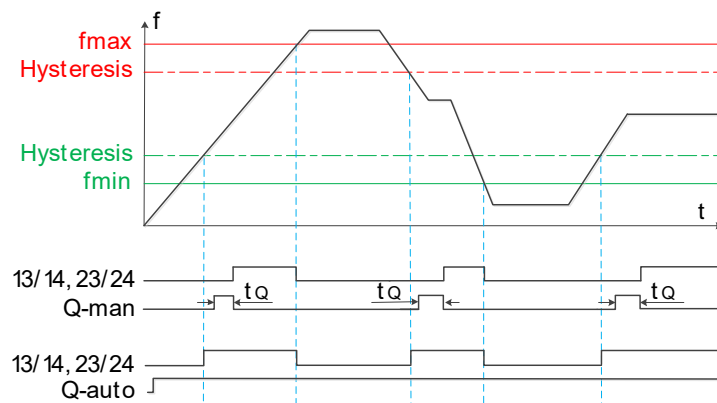

5.2 Switch-off delay

Optionally, you can set a switch-off delay t_v from 0s to 2s for the enable current path. The switch-off delay time expires as soon as an overrange or underrange is detected (Fig.5.1). During this time, the enable contacts remain closed and the "SPEED" LED flashes. When the switch-off delay time is expired, the enable current path opens.

If the speed reaches the target range during the switch-off delay time, the contacts remain closed and the switch-off delay time is reset.



CAUTION

Note that changing the switch-off delay affects the reaction time of the safety function!



Note

The switch-off delay time is not started when the shutdown occurs due to an internal or external fault.

5.2.1 Frequency limit during the switch-off delay

Motor frequency overshoots can be limited during the switch-off delay by setting a frequency limit. If the motor frequency exceeds this limit, the enable contacts open immediately.

Example:

$f_{max} = 100\text{Hz}$, Frequency limit during the switch-off delay = 50%

=> Effective frequency limit during the switch-off delay = 150Hz

5.3 Switch-on delay

Optionally, you can set a switch-on delay t_E from 0s to 10s for the enable current path. The switch-on delay time expires as soon as the frequency is within the desired range and an ena-

ble occurs by means of the acknowledgment input. During this time, the enable contacts remain open and the "SPEED" LED flashes.

When the switch-on delay time is expired, the enable current path closes.

If you have also selected the "Start-up monitoring" function, the outputs only switch on after the switch-on delay time has expired. Only then is the start-up monitoring active.

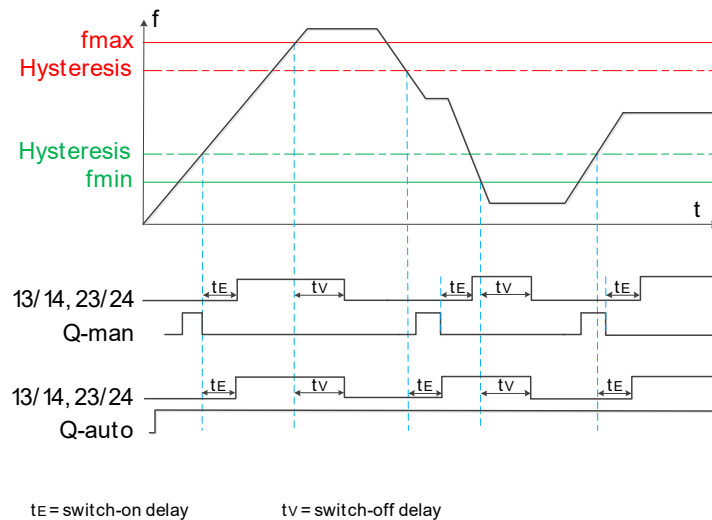

Figure 5-1

5.4 Advanced settings

5.4.1 Measurement frequency

Application dependent disturbances (e.g., vibrations or frequency overshoots) can adversely affect the measurement process. This can lead to unintentional shutdowns. To ensure availability in the case of faulty applications, you can adjust the parameters

- Frequency threshold
- Number of measuring cycles

The parameter determines with how many measurements the measured value is formed before it is switched off.

You can change the number of measuring cycles in the configuration software. You also define from which frequency this number should be valid.

Below this frequency, a single measurement is always used.

This multiple measurement has no influence on the switch-on behavior. Switching on takes place after one measuring cycle.

Default setting: 3 measuring cycles at frequencies > 30Hz

Maximum number of measuring cycles: 4



CAUTION

The set factor is multiplied by the measuring time of the system and influences the reaction time of the safety relay.

Few measuring cycles = short reaction time due to fast measuring value formation, but more prone to external disturbances

One measuring cycle = fastest reaction time

Many measuring cycles = long system reaction time but robust measurement

5.4.2 Sensitivity

Change these parameters only after consultation with the DINA Elektronik GmbH service.

5.4.3 Frequency comparison threshold

An internal error diagnosis checks the measurement results of the 2-channel frequency measurement for plausibility. This error diagnosis is carried out as standard starting from the frequency comparison threshold of 2Hz.

For some applications it may make sense to increase this threshold to avoid error messages. The parameterization software offers the option of shifting this up to a maximum of 100Hz. The possible setting is limited to 30% below the frequency limits.



Caution

Make sure that the operating range of your machine is above the frequency comparison threshold.

5.4.4 Coastdown monitoring

The coastdown monitoring can be activated and detects switching off the motor control while the motor is running at a relatively high speed as an error condition. In this case, the module goes into fault mode and the enable current path opens permanently.

The coastdown monitoring is useful when it is essentially monitored for standstill. If the motor control is switched off incorrectly at high speed, this prevents motor standstill from being incorrectly detected.

The configuration software is used to set the motor frequency threshold above which the coastdown monitoring should detect an error condition.

Example: $f_{max} = 5\text{Hz}$, threshold 64-times \Rightarrow frequency threshold: $5\text{Hz} \times \text{Factor } 64 = 320\text{Hz}$

The following figures illustrate the connections:

(Figure 5-2) If the last measured frequency before switching off the motor control is lower than the parameterized threshold f_A , the enabling current path closes with automatic acknowledgment after time t ($t = 1/f_{max} + 20\%$) because the process is tolerated.

(Figure 5-3) If the last frequency measured before the motor control is switched off is higher than the parameterized threshold f_A , the enabling current path closes with automatic acknowledgment after time t ($t = 1/f_{max} + 20\%$) and opens again after one second due to error detection. It is assumed that the engine is not yet at a standstill.

Legend

-  Motor is de-energized
- f_A frequency threshold
- f_{max} Maximum frequency
- 13/14, 23/24 enable current path
- t $1/f_{max} + 20\%$

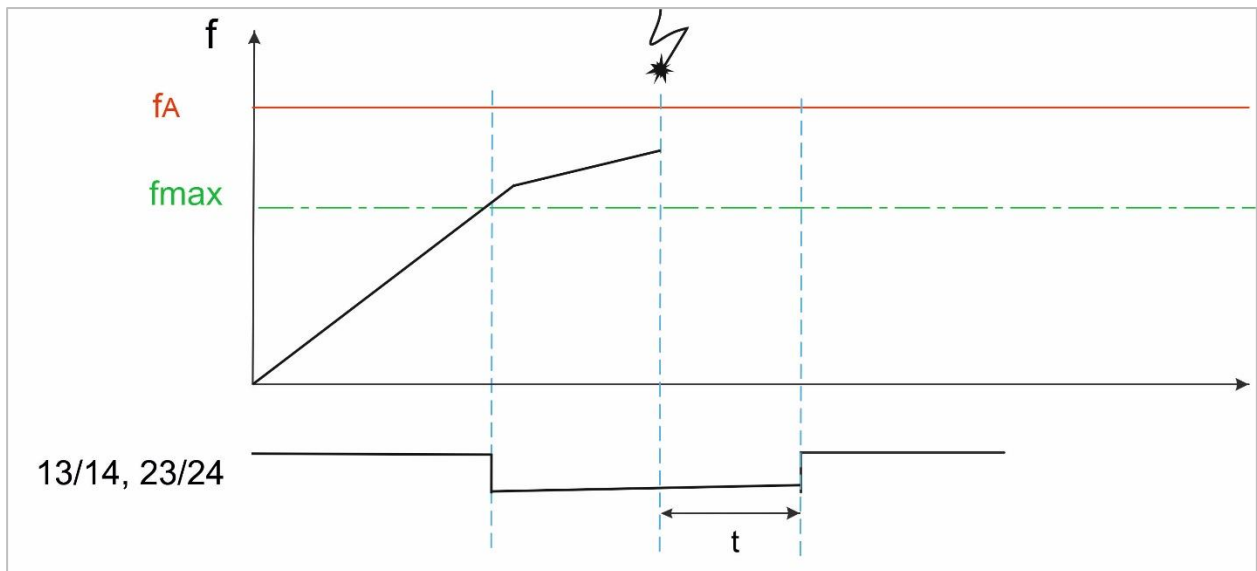

Figure 5-2

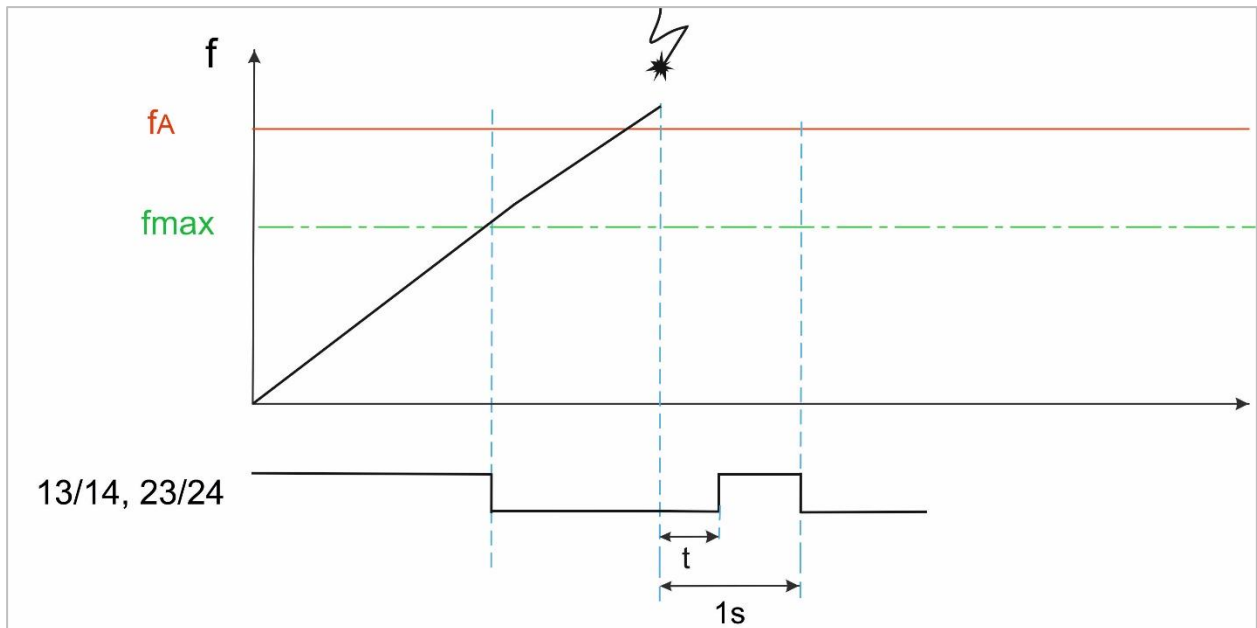

Figure 5-3

5.4.5 Phase monitoring

Phase monitoring enables fast wire break detection on U, V, W for 3-phase motors and frequencies between 5Hz and 100Hz.

Deactivate phase monitoring when operating single-phase AC motors.

5.4.6 Sensitivity Extended wire break detection

(only for 34PD11 and 34PD21)

This parameter can be used to adapt the detection of a wire break fault to different drive systems.

If the extended open-circuit fault is triggered when the motor is running (3 x flashing of LED 1 and LED 2) even though there is no open circuit, the sensitivity must be reduced.

Before changing this parameter, check whether there is actually no open circuit at terminals U, V, W.

5.5 Minimum switch-off time

The minimum switch-off time t_{min} is the time that the enable current path is at least open after triggering before it switches on again. It is 300ms.

5.6 Password

The transfer of the parameters and the validation function can be password protected. The password can contain a maximum of 8 characters.

5.7 Validation

To validate the safety function, a validation tool is available in the configuration software.

With this function, the limit values f_{max} and f_{min} are reduced or increased by 10%, 20% or 30%, thereby forcing a switch-off.

The validation requires the entry of the device password.

5.8 Diagnosis

In conjunction with the configuration software, diagnostics offers the following functions:

- Reading out values from the safety switching device during operation
- Reading out data which are relevant for switch-off

5.9 Display

The safety switching device indicates its operational readiness and the status of the enabling current path by the two-color LEDs "OK" and "SPEED".

See Table 5-1

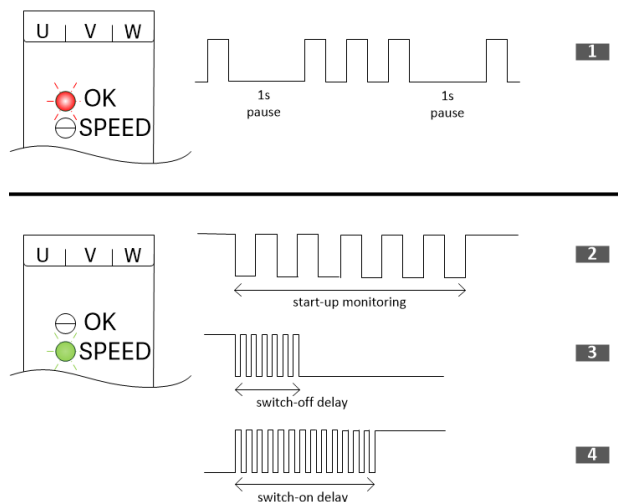

Legend



LED OK	LED SPEED	Flash-code	13/14, 23/24	Status	
		--	ON	acknowledged	in range
		--	OFF	not acknowledged	out of range

		2	ON	acknowledged, start-up monitoring active	out of range
		3	ON	acknowledged, off delay active	out of range
		4	OFF	acknowledged, on delay active	in range
		--	OFF	not acknowledged	in range
		1	OFF	error	See chapter Error messages and LED error codes
		1	OFF	error	See chapter Error messages and LED error codes
		--	OFF	device defect	

Table 5-1

5.10 Error messages and LED error codes

The safety switching diagnosed errors that cause the device to enter the safe state as follows:

- Flash-codes of the LED „OK“ and “SPEED” on the device.
- Error message in the configuration software

The flash code is repeated continuously after a pause of 1 s.

For the meaning of the individual LED codes and possible remedy, refer to Table 5-2.

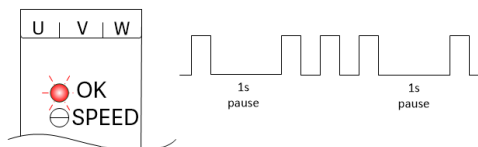

5.11 Remedy in the event of an error

With manual acknowledgement, the errors (x) marked in Table 5-2 can be deleted. Proceed as follows:

- ▶ Eliminate the error.

- ▶ Connect the acknowledgement input Q to 24V for at least 10 s and a maximum of 16 s.
- ◀ After 10 s, the LEDs flash green.
- ◀ The fault memory is deleted as soon as input Q is switched off.

When the OK LED lights up green, the safety relay is ready for operation again.



Note

Deletion via the acknowledgement input Q is only possible if the acknowledgement mode "manual" has been parameterized.

Otherwise, the safety relay must be restarted to clear the error.

Flash-Code		Meaning / diagnostic information from the software	erasable	Remedy
LED OK	LED SPEED			
1 x flash	–	incorrect power supply	–	Check power supply UB = 20.5V - 26,5V DC
2 x flash	–	transmission error parameter	–	Check <ul style="list-style-type: none"> • interface • connection cable • Have the parameters been confirmed before transfer?
3 x flash	–	incorrect acknowledge signal at input Q	–	Check the wiring at input Q for cross or short circuits. For manual acknowledgment: Check whether the start signal is within the time range of min. 150ms to max. 20s.
4 x flash	–	open-circuit on U, V, W	✓	Check the wiring at the measuring inputs for <ul style="list-style-type: none"> • short circuit • cross-connection • wire break

5 x flash	–	transmission error password	–	The password was not confirmed. Transfer the password again.
6 x flash	–	Relay error	–	Send the device to DINA Elektronik for testing
7 x flash	–	single-channel error The signals at the measuring inputs are different.	✓	Check the wiring at the measuring inputs for <ul style="list-style-type: none"> • short circuit • cross-connection • wire break
8 x flash	–	Frequency > 1500Hz Frequency > 1800Hz at ID-No. 34PDx4	✓	Check the frequency at the measuring inputs.
9 x flash	–	internal error	–	Send the device to DINA Elektronik for testing.
10 x flash	–	internal hardware error	–	Send the device to DINA Elektronik for testing.
1 x flash	1 x flash	Phase monitoring error	✓	Check the parameter „Phase monitoring“. Deactivate the parameter for single-phase motors.
2 x flash	2 x flash	Coastdown error with active coastdown monitoring	✓	Check the parameter „coastdown monitoring“.
3 x flash	3 x flash	Extended wire break detection on running motor	✓	Check the wiring at the measuring inputs for wire break.
4 x flash	4 x flash	Error on input I1 or I2 Inputs are >1s unequal	✓	Check inputs I1 and I2 for identical signals.
5 x flash	5 x flash	Hardware error	–	Send the device to DINA Elektronik for testing.
6 x flash	6 x flash	Internal error	–	Send the device to DINA Elektronik for testing.

Table 5-2

6 Applications

The DN3PD2 safety relay can be used on asynchronous and synchronous motors.

Motor with frequency converter

The operation on electric power drive systems with adjustable speed is possible.



Note

Please note that the DN3PD2 is not suitable for use with frequency converters if the motor driver output stage generates the PWM switching frequency using thyristors. As a rule, however, MOSFET, SiCFET or IGBT transistors are installed in the driver output stage. In these cases, there are no restrictions.

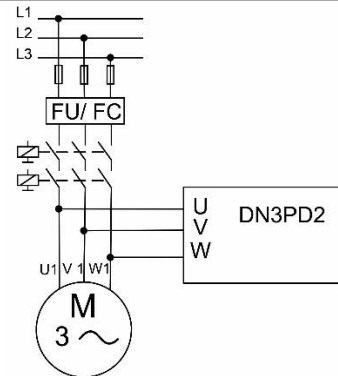

Motor with star-delta circuit

Operation on motors with star-delta connection or pole changeover is possible.

- ▶ Ensure that the measurement inputs U, V and W are always connected directly to the motor connections.
- If the motor windings are not connected as a star or delta connection in a de-energized state for >2s, the DN3PD2 detects a wire break error.



Note

For pole-changing motors, please note that DN3PD2 detects the frequency and not the speed!

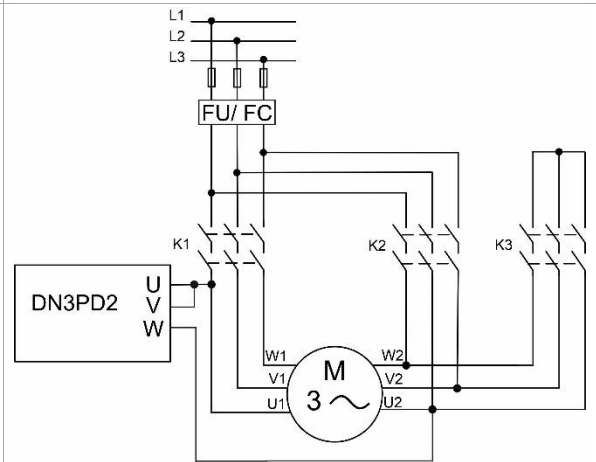

Single-phase motor

Operation on a single-phase motor is possible.

- ▶ Bridge the measuring inputs U and V and connect them directly with the motor connector U1.
- ▶ Connect the measuring input W directly with the motor connector U2.

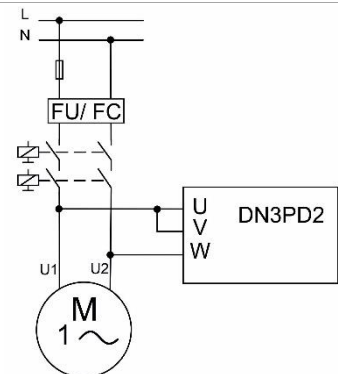

7 Configuration and startup

To configure the DN3PD2 safety switching device, use the GO:BEYOND configuration software.



WARNING

Danger through incorrectly set parameters

Incorrectly set parameters for motion monitoring can result to dangerous machine or system states.

- Enter the parameters according to the connected hardware.
 - Carry out a function test after parameterization and after every change in the parameterization as part of the validation.
-



Note

Assistance during validation and commissioning can be a separate measuring device or the diagnostic function (display of actual and limit values) in conjunction with the validation function in the configuration software.

The diagnostic function is **not** safety-related.

7.1 System requirements

The configuration software is compatible with the following operating systems

- MS Windows 8
- MS Windows 10
- MS Windows 11

Hardware requirements:

Hard disk space	min. 1 GB
Main memory	min. 2 GB
Resolution	1920 x 1080 px
Scaling	100%
Interface	USB

7.2 Installation of the Configurations-Software

The configuration software can be found in the download area of the article at dina.de/en/downloads.

Always work with the latest version of the software.

Installing the software:

1. Download the software.
2. Start the installation.
3. Follow the instructions in the installation wizard.
4. Choose the language about “Settings” in the start screen.

7.3 Connection to the PC

The USB interface is used for communication between the safety switching device and the

configuration software. Use a suitable connecting cable to connect the module to the PC. The interface is suitable for standard Mini-USB-A cables.

7.4 Start screen

The configuration software has the following start screen.

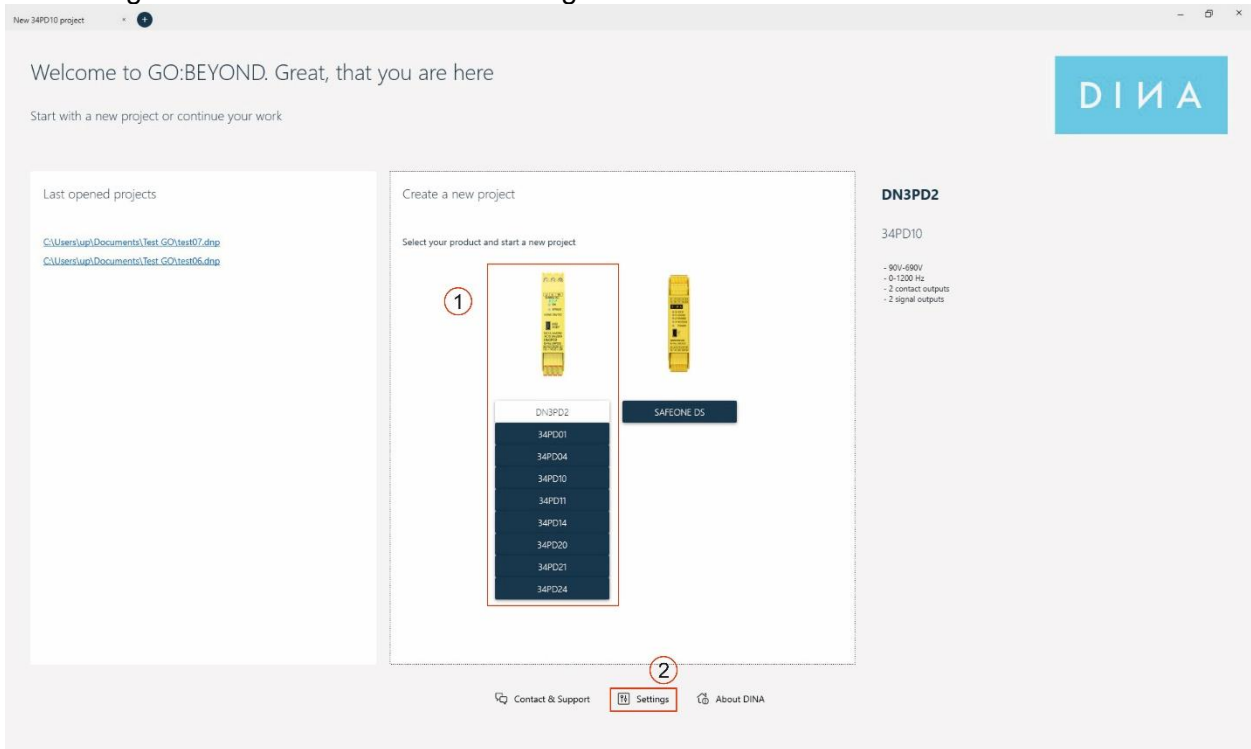

1 Hardware selection

To create a new project, click the button for DN3PD2 and select the corresponding ID number.

2 Settings

You can select the language (German/English/Italian) under “Settings” in the start screen.

7.5 User interface

The configuration software has the following user interface.

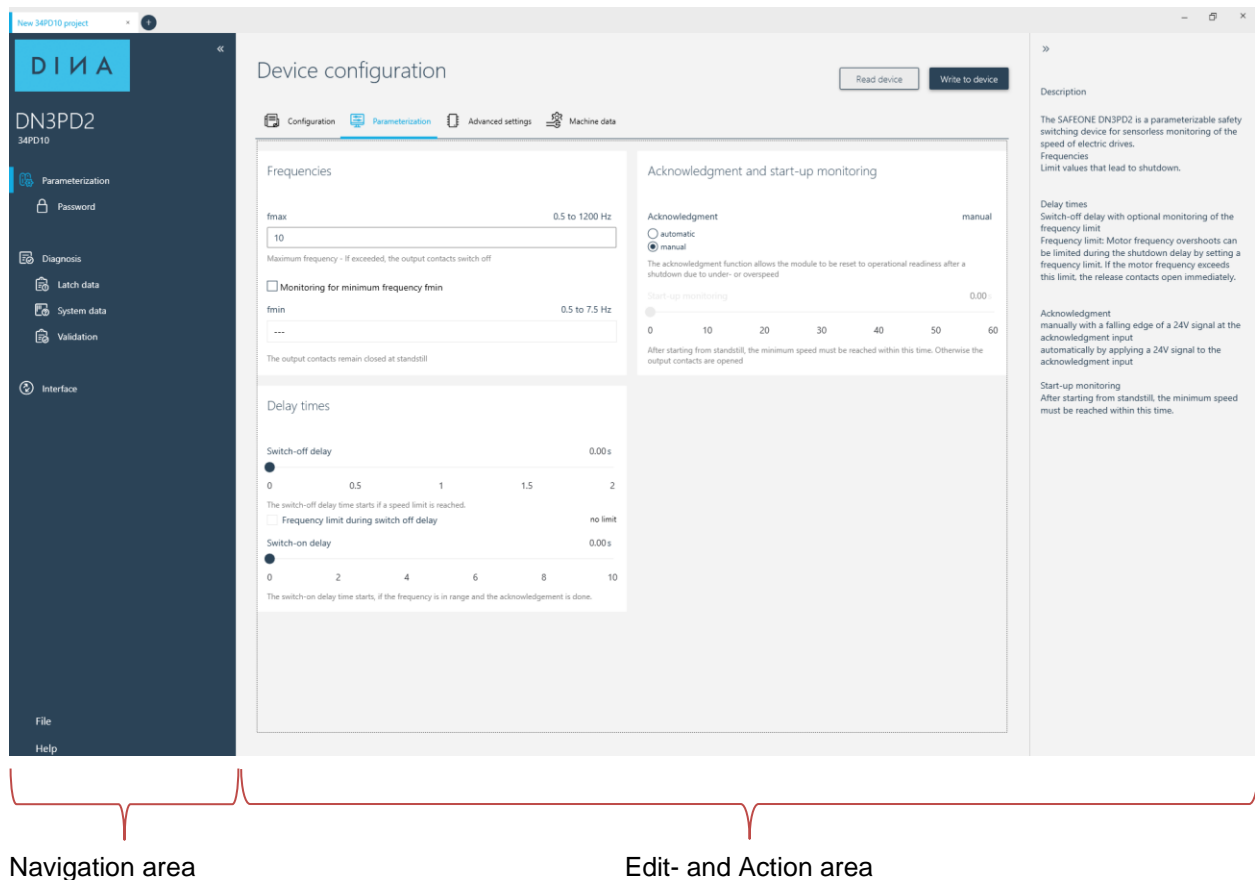

Navigation area

In the navigation area you can select the following areas:

- Parameterization edit of device- and application
- Password password management
- Diagnostics display of online values, switching states, error messages
- Latch data display of the switch-off-relevant data
- Validation setting of validation levels
- Interface selection of the interface
- File open/ import from other plugins/ save/ print/ close a project
- Help information on the software version, documentation and contact

Edit- and Action area

This area offers the following functions:

- Device configuration Edit parameters
- Read device Read out the parameter from the module to the configuration-software
- Write to device Transmit the parameter from the configuration-software to the module

7.6 Create a project

- ▶ Start the configuration software.
- ▶ Select the device.
- ▶ Open the "Interface" menu item and select the COM port.
- ▶ Open the "Parameterization" menu item.
- ▶ Edit the parameter.
- ▶ Transmit the project to the device with the button „write to device“.
- ▶ There is always a password prompt. If no password is saved, confirm the query with "ok".
- ▶ Verify the correct parameters and confirm the settings.
- ◀ The data is transferred to the device.
- ▶ Save the project.

7.7 Parameterization

You can make the following settings on the configuration software

Parameter	Range	Note
Project name	maximum 8 signs	absolutely necessary
Author	maximum 8 signs	
Date	mm.dd.yy	
Password	maximum 8 signs	
fmax, fmax1, fmax2 *)	0,5Hz – 1200 Hz or 100Hz – 1650Hz	One decimal place can be entered.
fmin *)	>= 0,5Hz	Can be deselected
Acknowledgment	- manual - automatic	Automatic acknowledgment with start-up monitoring: fmin ≥ 1.1 Hz
Start-up monitoring	0-60s	0 ≙ start-up monitoring is deactivated. Enable current path closes at > fmin and < fmax.
Switch-off delay	0-2s	
Frequency limit during switch-off delay	fmax + (1% bis 100% of fmax)	
Switch-on delay	0-10s	
Advanced settings		
Frequency threshold	16 steps	
Number of measuring cycles	1-4	

Parameter	Range	Note
sensitivity	Mode 1-4	4 \triangleq maximum measuring sensitivity
Frequency comparison threshold	2Hz – 100Hz	Maximum 30% below fmin or fmax1
Coastdown monitoring	2 – 128-times of fmax/fmax1	
Phase monitoring	On/off	Must be deactivated for single-phase motors
Extended wire break detection	1- 4	4 \triangleq high sensitivity
Machine data		
Axis type	Linear axis, spindle, rotary axis	
Number of pole pairs	1-99	
Ratio	0.01-99999	
Radius	1-9999	
Pitch	0.001-9999	
Minimum speed		Depending on the machine data and the permitted maximum frequency.
Maximum speed		

*)

- To determine the switching thresholds, the number of pole pairs must be taken into account: $f \text{ [Hz]} = (n \text{ [U/min]} / 60) \times \text{number of pole pairs}$
Example: $5000 \text{ rev/min} \times 3 \text{ (number of pole pairs)} / 60 = 250\text{Hz}$
- Asynchronous motors have a load-dependent slip between the motor speed and the rotating field frequency. This must be taken into account when parameterizing the threshold frequencies (fmin and fmax).

7.8 Machine data

The "Machine data" calculation tool can be used to determine fmin and fmax.

Enter the machine-specific data and the tool calculates the associated frequencies. The machine data can be saved in the device. Check the checkbox "Take over machine data". Then it is no longer possible to enter the frequencies directly in the "Parameterization" menu.

7.9 Edit and Change password

Protect your safety relay against unauthorized access with a device password.

- ▶ Open the menu item "Parameterization password"
- ▶ Enter the current password. If no password is assigned, the field can remain empty.
- ▶ Edit a new password and confirm it.
- ▶ Click the button "Write to device".

The password is now stored in the device and must be specified when transferring a new project or when validation.

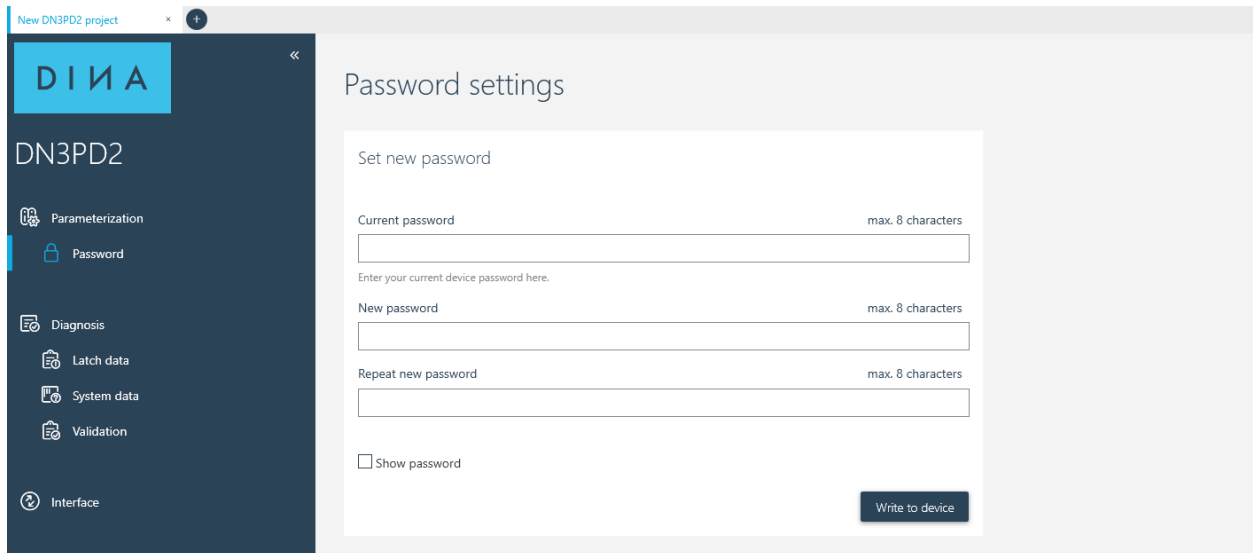

7.10 Read out the project

You can read out the parameterization saved on the safety relay.

No password is required for reading out.

- ▶ Start the configuration software.
- ▶ Select the device.
- ▶ Open the "Interface" menu item and select the COM port.
- ▶ Open the "Parameterization" menu item.
- ▶ Click the "Read out device" button.

7.11 Diagnosis

The current device states are displayed in the "Diagnosis" view.

- ▶ Select the "Diagnosis" menu.
- ▶ Click on "Start"



- | | |
|--|--|
| <p>1 Diagnosis start/stop</p> <p>2 Motion or time diagram</p> <p>2a Unit switching</p> <p>3 Status display of inputs and outputs</p> <p>4 Help area and error list</p> | <p>Start or stop the diagnosis.</p> <p>For visual representation of the movement:
 Blue curve: Actual frequency
 Red lines: fmin und fmax</p> <p>Representation of the actual and limit values in Hz or corresponding speed unit</p> <p>13/14, 23/24: Status of the enabling current path for speed monitoring</p> <p>O1 or I1: Status of the signal output O1 or of the input I1</p> <p>O2 or I2: Status of the signal output O2 or the input I2</p> <p>Q: Status of the acknowledgment input Q</p> <p>Help texts and occurred errors</p> |
|--|--|

7.11.1 Latch data

When the safety function is triggered, the shutdown-related data is saved in the device. You can read the data for diagnostic and servicing purposes. The data is stored until the safety function is triggered again.

- ▶ Select the menu „Latch data“.

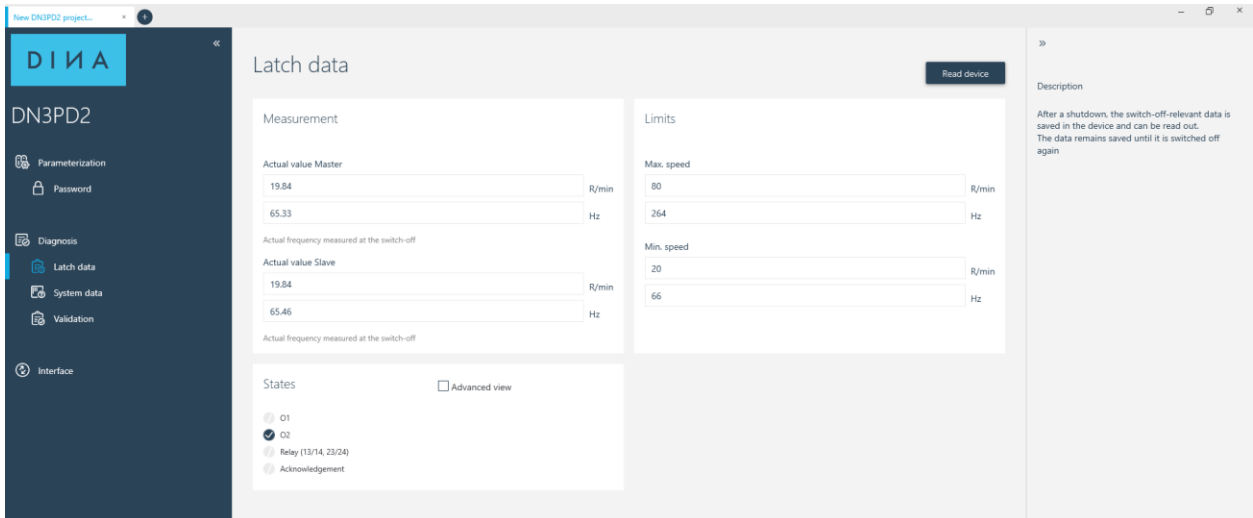

Latch data

shutdown-related data

- Speed and frequency at the shutdown time
- Status of the inputs and outputs
- Advanced view for servicing purposes

7.11.2 System data

Under “System data”, you can read project data and hardware-specific data from the connected device.

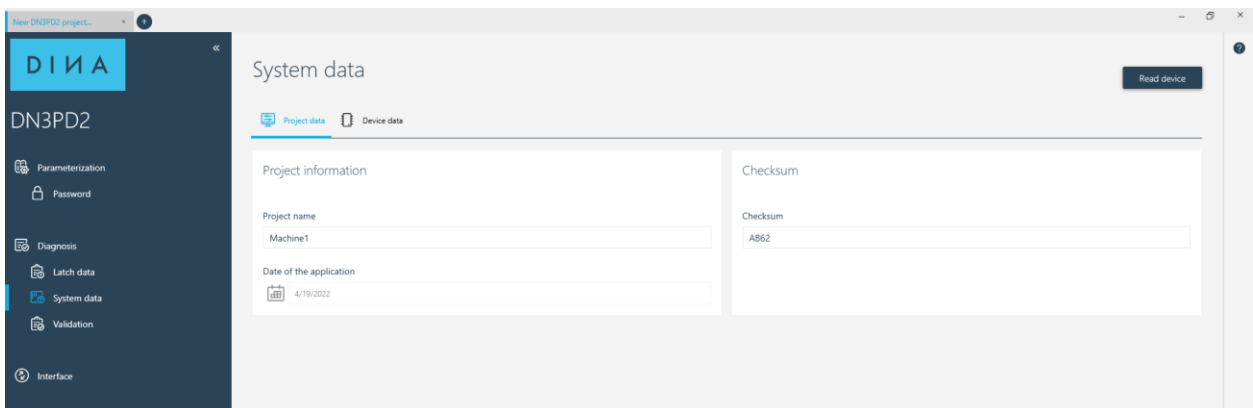

Project data

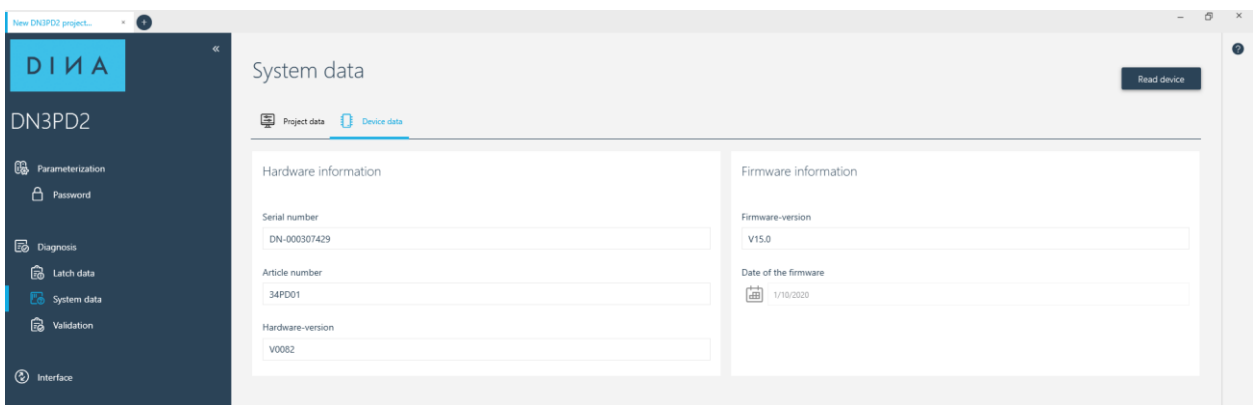

Device data

7.11.3 Validation

A validation function is available in the configuration software to validate the safety function. You can reduce or increase the limit values f_{max} and f_{min} by 10%, 20%, or 30%, thereby forcing a shutdown.

Validation requires you to enter the device password.

- ▶ Select the validation level
- ▶ If the device is password-protected, you will be asked to enter a valid password.

The states are recorded and you can print out a report.

The validation level is automatically reset after 10s.

- ▶ Click the “Stop” button to stop the recording



Alternatively, you can start an automatic validation.

- ▶ Click the “auto. Start “ button.
- ◀ This successively runs through the validation levels and resets them. Automatic validation stops after one run.



Note

Validation is not possible if $f_{max} < 1\text{Hz}$ or if reducing of f_{max} and increasing of f_{min} would result in $f_{min} > f_{max}$.

8 Example of application

Speed monitoring of a 3-phase motor

- Release of output contacts 13/14, 23/24 if adhered to
 - the minimum frequency to be monitored
 - the maximum frequency to be monitored
- Manually monitored start
- Monitoring of external positively guided contactors K1/K2



Note

Make sure that the measurement inputs U, V, W are permanently connected to the motor windings.

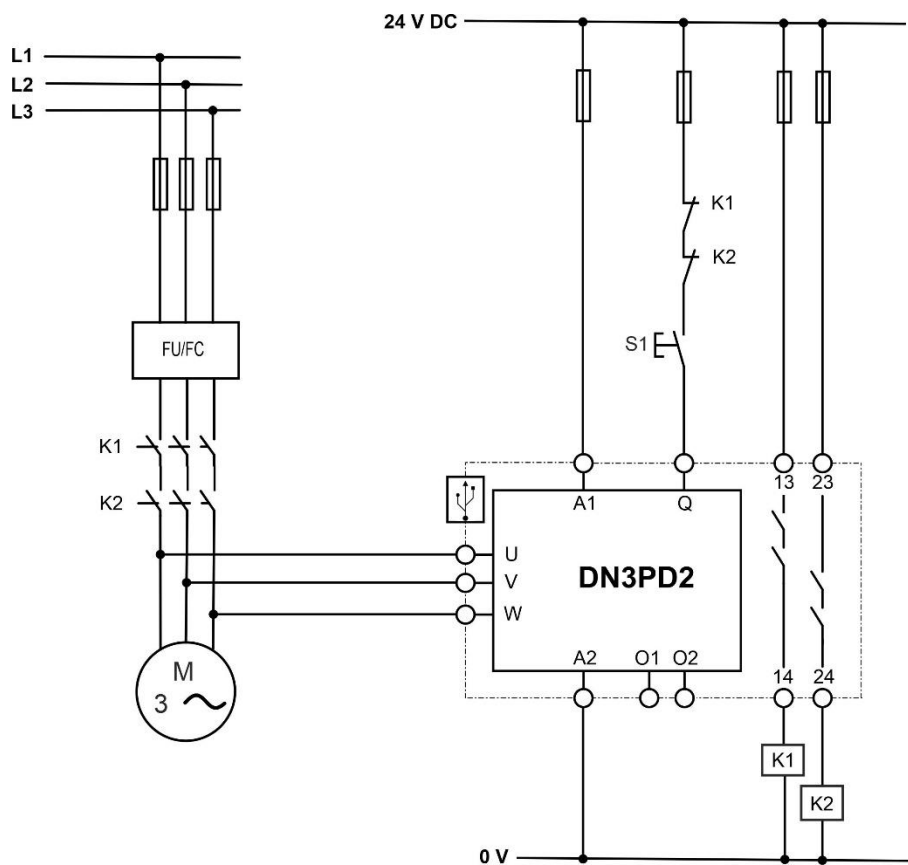

Legend:

- S1 manual acknowledgment facility
- K1/K2 positively guided contactors
- FU/FC frequency inverter
- M motor

9 Order information

Description	Product	ID-No.
Speed monitoring, sensorless 90V – 690V, 0.5 -1200 Hz, 2 contact outputs, 2 signal outputs, USB interface	DN3PD2	34PD010
Speed monitoring, sensorless 24V – 120V, 0.5 -1200 Hz, 2 contact outputs, 2 signal outputs, USB interface	DN3PD2	34PD11
Speed monitoring, sensorless 90V – 690V, 100 -1650 Hz, 2 contact outputs, 2 signal outputs, USB interface	DN3PD2	34PD14
Speed monitoring, sensorless 90V – 690V, 0.5 -1200 Hz, 2 contact outputs, 2 inputs, USB interface	DN3PD2	34PD20
Speed monitoring, sensorless 24V – 120V, 0.5 -1200 Hz, 2 contact outputs, 2 inputs, USB interface	DN3PD2	34PD11
Speed monitoring, sensorless 90V – 690V, 100 -1650 Hz, 2 contact outputs, 2 inputs, USB interface	DN3PD2	34PD24

10 Technical data

10.1 Supply

Operating voltage U_B	24 V DC (-15/+10%)
Current consumption at 24V	< 80 mA
Power consumption at A1/A2	1,9 W

10.2 Digital inputs

Inputs	Q, I1, I2
Input voltage range "1" signal	19 V DC...30 V DC

Current consumption	typ. 4 mA (at UB)
Input voltage range "0" signal	0 V DC...5 V DC

10.3 Measuring inputs

Inputs	U, V, W	
Input voltage range At 34PD11 and 34PD21	90V to 690V AC 24V to 120V AC	
Current consumption	0,35mA at 690V AC	
Limit frequency at U, V, W	fmin	fmax
ID-No. 34PD10, 34PD11, 34PD20, 34PD21	0,5 Hz	1200 Hz
ID-No. 34PD14, 34PD24	100 Hz	1650 Hz
Minimum-PWM	2kHz	
Measurement uncertainty	1%	
Switching hysteresis	10%	

10.4 Signal outputs

Outputs	O1, O2 Non safety
Voltage range	UB-1V
Switching current	≤ 100mA shot-circuit and overload protection

10.5 Contact outputs

Outputs	13/14, 23/24
Contact material	AgSnO ₂
Output guidance	
Minimum switching current	10 mA

Switching capacity in accordance with IEC 60947-5-1	DC13: 4A/24V AC15: 5A/230V
Mechanical service life	10 ⁷ switching cycles
Electrical life	10000 cycles (EN 61810-1, 6A 250 V AC, cos φ =1, 80°C) 10000 cycles (EN 61810-1, 6A 24V DC, resistive, 80°C) 6000 cycles (UL508, B300, 80°C) 6000 cycles (UL508, R300, 80°C)
Contact fuse	6 A gL/gG
Typical response time	Number of measuring cycles x (period (<i>reciprocal value of the set frequency</i>) + max. 2ms cycle time) + max 10ms relay switch-on time

10.6 General data

Type of protection (housing and terminals)	IP 20
Type of protection (place of installation)	min. IP 54
Clearance and creepage distances between circuits	In accordance with DIN EN IEC 60664-1:2022-07
Rated insulation voltage (13/14, 23/24)	400V
Rated surge voltage/insulation	Basic insulation 6kV: between all current paths and housing Safe insulation, reinforced insulation 8kV: between U, V, W and USB interface between U, V, W and A1, A2, O1, O2, Q between U, V, W and 13/14, 23/24
Degree of contamination	2
Overvoltage category	III
Housing material	Polyamide (PA), not reinforced

10.7 Connection data

Terminals	Push-in, pluggable		Screw, pluggable
Number of positions	4	5	3
Conductor cross section	0,25 – 2,5mm ²	0,25 – 1,5mm ²	0,25 - 2,5mm ²
AWG conductor cross section	24...12	24...16	24...12
Min/max tightening torque	-	-	0,5Nm/0,6Nm
Conductor type	Flexible with end sleeves		
Stripping length	8 mm		

10.8 Environmental conditions

Operating temperature	-20 °C to +55 °C
Storage temperature	-40 °C to +85 °C
Attitude of place of use	< 2000 m above sea level
Shock resistance	15g

10.9 Dimensions

B x H x T	22,5 x 114 x 111 mm (0.886 x 4.488 x 4.370 in)
Size of DIN rail	35,0 mm (1.378 in)
Weight	130g

10.10 Safety technical data

Stop category in accordance with IEC 60204	0 and 1
--	---------

10.11 Safety-related parameters in accordance with DIN EN ISO 13849-1:2023

Category	4	
Performance Level	e	
MTTFd [a]	at 34PD1x	at 34PD2x
DC13, 1A, 2 cycles/h	308	291
AC15, 3A, 2 cycles/h	261	248

10.12 Safety-related parameters in accordance with EN ISO 61508- High Demand

HFT	1	
SIL	3	
PFHd [h]	at 34PD1x	at 34PD2x
DC13, 1A, 2 cycles/h	$5,52 \times 10^{-9}$	$5,85 \times 10^{-9}$
AC15, 3A, 2 cycles/h	$5,86 \times 10^{-9}$	$6,19 \times 10^{-9}$
Demand rate	< 12 months	
Proof-Test-Interval	240 months	

10.13 Safety-related parameters in accordance with EN ISO 61508- Low Demand

HFT	1	
SIL	3	
PFDavg	at 34PD1x	at 34PD2x
DC13, 1A, 2 cycles/h	$1,66 \times 10^{-4}$	$1,92 \times 10^{-4}$
AC15, 3A, 2 cycles/h	$1,68 \times 10^{-4}$	$1,94 \times 10^{-4}$
Proof-Test-Interval	240 months	

11 Installation and removal

11.1 Installing a module

11.1.1 Overview

- (A) 70-75 mm (2,756-2,953 in)
- (1) Top hat rail
- (2) Locking slider
- (3) Cable duct

Procedure

- ▶ Hook the module onto the top hat rail (1) and press it downward.
- ▶ The locking slider (2) engages under the top hat rail.

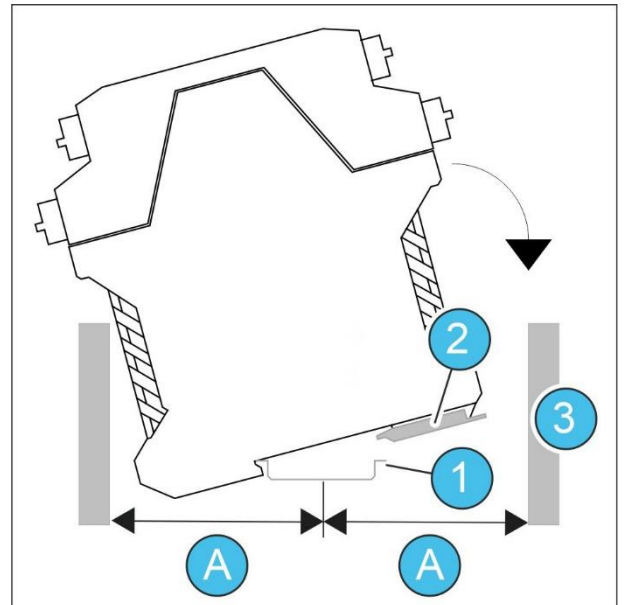

11.2 Removing a module

Procedure

- ▶ Use a screwdriver (1) to move the locking slider away from the module.
- ▶ Move the module upward and remove it from the rail.

