

DN3PD1

Original Instruction Manual
valid for ID-No: 33PD02

Safety switchgear
to monitor the speed of three-phase and
single-phase motors without sensor



EU-Konformitätserklärung

EC-Declaration of Conformity

DINA Elektronik GmbH
 Esslinger Str. 84
 72649 Wolfschlugen
 Germany
 Phone +49 7022 95170
 Fax +49 7022 9517700
 info@dina.de
 www.dina.de

Wir erklären, dass folgendes Produkt die einschlägigen Harmonisierungsrechtsvorschriften der Union erfüllt.
 We declare that the following product is in conformity with the relevant Union harmonisation legislation.

Produkt/product	Beschreibung/description
DN3PD1	Sicherheitsschaltgerät zur sensorlosen Drehzahlüberwachung bei Drei- und Einphasen Motoren Safety switchgear unit to monitor the speed of 3-phases and single phase motors without sensor

EU-Richtlinien/EC- directives	Angewandte Normen/Applied standards
2006/42/EG Maschinenrichtlinie/Machinery-Directive 2014/30/EU EMV-Richtlinie/EMC-Directive 2011/65/EU RoHS Richtlinie/RoHS-Directive	EN ISO 13849-1:2015 IEC 62061:2015 IEC 61800-5-2:2016 IEC 61508: Parts 1-7:2010 EN 50178: 1997 EN 60204-1:2006 + A1:2009 + AC:2010 EN 60947-5-1:2010 EN 61326-1 :2013 EN 61326-3-1:2008 + Entwurf 2015 SIL3 GS-ET-20: 2016-10

Notifizierte Stelle/notified Body	EG Baumusterprüfbescheinigung/EC Type-Examination certificate
TÜV Rheinland Industrie Service GmbH Am Grauen Stein 51105 Köln Germany NB 0035	Reg.-Nr./No.: 01/205/5650.01/18

Wolfschlugen, 24.07.2018



Dirar Najib
 Geschäftsführer/CEO

Content

1	Intended Use	6
1.1.	Approvals	6
1.2.	Safety parameters	6
1.3.	Ordering data	6
2	Safety regulations	7
3	Important information and validation	7
4	Function description	8
4.1.	Switching threshold	8
4.2.	Start-up monitoring	8
4.3.	Minimum switch-off time	8
4.4.	Acknowledge function	8
4.5.	Functional diagram	9
4.6.	Schematic, operating element and display	10
4.7.	Terminal description	10
5	Applications	11
5.1.	Motor with frequency converter	11
5.2.	Motor with star-delta circuit	11
5.3.	Single-phase motor	11
5.4.	Synchronous motor	11
6	Mounting and removal	12
6.1.	Wiring	12
6.2.	Commissioning	12
6.3.	Example of application	12
7	Parameterization of the switching thresholds	14
7.1.	Important notes for parameterization	14
7.2.	Table of frequencies	14
7.3.	Configuration of the switching threshold and acknowledgement	15
7.4.	Example for configuration	16
8	Diagnostics	16
8.1.	Error report	16
9	Technical data	18
9.1.	Ambient conditions	18
9.2.	Input data	18
9.3.	Output data	18
9.4.	General data	18
9.5.	Connection data	18
9.6.	Relay load curve	19
10	Dimensions	19



Always read the additional applicable online documentation before working on/with the safety switchgear. Make sure you always work with the valid documentation. This is available online at <http://www.dina.de/downloads/>



Dispose of the device according to the national environmental regulations.

Symbol and Notes:



WARNING

Observe the safety regulations and installation notes in the corresponding section.



INFO

Observe the notes in the corresponding section.

Version overview / Change history

Version	Date	valid for ID-No	Innovations / changes
0743	2018-12-06	33PD02	
0743.3	2020-06-16	33PD02	Error message if $f > 800\text{Hz}$
0743.3	2021-06-09	33PD02	Limitations when using Synchronous motors

1 Intended Use

- Safety switchgear to monitor the speed of three-phase and single-phase motors without sensor.
- Two speed thresholds are possible: minimum speed and maximum speed.
- The unit meets Cat. 4/ PL e acc. to ISO 13849-1, SIL (CL) 3 acc. to IEC 62061 and IEC 61508.
- Usage in safety current circuit according to VDE 0113 T.1

1.1. Approvals



1.2. Safety parameters

The unit meets Cat. 4/ PL e and SIL (CL) 3.

Parameter	Value	Note
PFH	1,56 E-09 1/h	1,6 % von SIL 3
MTTF_d	553 a	HIGH
DC_{avg}	95%	(HIGH)

table 1-1: Safety parameters

1.3. Ordering data

	Description	Type	ID-No.:
Speed monitoring, sensorless	0-600Hz, 2 contact outputs, start-up monitoring, switch-off time 01	DN3PD1	33PD02-01
Speed monitoring, sensorless	0-600Hz, 2 contact outputs, start-up monitoring, switch-off time 02	DN3PD1	33PD02-02

2 Safety regulations

- The device may only be installed and commissioned by an electrician or trained persons who are familiar with these operating instructions and the applicable regulations regarding work safety and accident prevention.
- Observe the VDE, EN and local regulations, particularly with respect to the protective measures.
- Failure to observe the regulations may result in death, severe bodily injury or extensive property damage.
- For emergency-stop applications, either the integrated function for restart interlock must be used or automatic restarting of the machine must be prevented by means of a higher-level control.
- During transport, storage and operation adhere to the conditions specified in EN 60068-2-1, 2-2!
- Unauthorized modifications shall render any warranty null and void. Dangers may thereby arise that could result in severe injuries or even death.
- Install the device in a control cabinet with a protection class of at least IP54! Dust and moisture may otherwise result in impaired functions. Installation in a control cabinet is mandatory.
- Ensure adequate protection circuits at output contacts for capacitive and inductive loads!
- The device is to be installed taking into account the distances required per DIN EN 50274, VDE 0660-514.
- During operation, switching devices carry dangerous voltage. Do not remove protective covers.
- Replace the device after the first malfunction.
- Properly dispose of the device at the end of its service life.
- If these regulations are not adhered to or in the event of improper use, DINA Elektronik GmbH accepts absolutely no liability for the resulting property damages or personal injury.
- Save this product information!

3 Important information and validation

- The product described here was developed to perform safety-related functions as part of a complete system.
- The complete system consists of sensors, evaluation and message units as well as concepts for safe shutdowns.
- It is the responsibility of the manufacturer of a system or machine to ensure the proper overall function.
- The manufacturer of the system is required to test and to document the effectiveness of the implemented safety concept within the complete system.
In this case, it must be checked whether the release contacts open when exceeding or falling below the thresholds.
- This verification is to be performed after every modification to the safety concept or to safety parameters.
- DINA Elektronik is not in the position to guarantee the properties of a complete system that was not designed by DINA.
- DINA Elektronik GmbH also accepts no liability for recommendations that are given or implied by the following description.
- No new guarantee, warranty or liability claims that extend beyond DINA's general delivery conditions can be derived on the basis of the following description.
- To avoid EMC disturbances, the physical environmental and operating conditions at the installation location of the product must comply with section EMC of DIN EN 60204-1.
- When using contact outputs, the safety function must be requested once a day at PL e and once a year at PL d according to IEC 61800-5-2.
- Observe the general technical data at the end of this operating manual.

4 Function description

The two-channel evaluation unit of the safety switchgear module measures the frequency of the effective rotating field of the motor at the measuring terminals L1, L2, L3.

If the parameterized switching threshold frequencies are exceeded or undershot (V-LIMIT 1 and V-LIMIT 2), or an internal or external fault exists, the enabling current paths 13/14, 23/24 open immediately. The device is in safe switching state.

The monitoring of V-LIMIT 1 can be deselected. Then the output contacts remain closed at standstill.

Asynchronous motors have a load-dependent slip between the motor speed and the rotating field frequency. This must be observed by the configuration of the switching threshold (V-LIMIT 1 and V-LIMIT 2).

4.1. Switching threshold

Two switching thresholds are configurable.

V-LIMIT 1: minimum speed

If V-LIMIT 1 is undershot, the output contacts (13-14 / 23-24) switch off.

They switch on again after the acknowledgment via the acknowledgment input Q.



Depending on the acknowledgment mode, the switch-on-conditions differ. Please note the chapter "Function diagram".

V-LIMIT 2: Maximum speed

If V-LIMIT 2 is exceeded, the output contacts (13-14 / 23-24) switch off.

They switch on again after the acknowledgment via the acknowledgment input Q, if V-LIMIT 2 (minus hysteresis) is undershot.

Switching on takes place at the earliest after 0.5 seconds. (see chapter minimum switch-off time)

4.2. Start-up monitoring

The startup monitoring t_A is a time limit within which the actual speed must be greater than V-LIMIT 1. If the minimum speed is not reached during this time, the enable current path opens again.

The start-up monitoring time is fixed and is 60s. It is not retriggerable, it cannot be restarted while it is running.

The start-up monitoring time starts

- In case of manual acknowledgment: with the falling edge of the acknowledge signal
- In case of automatic acknowledgment: if the actual speed is $> 1\text{Hz}$



The startup monitoring is omitted if V-LIMIT 1 has been deselected.

4.3. Minimum switch-off time

The minimum switch-off time t_{\min} is the time that the enable current path is at least open after triggering before it switches on again. It is 0.5s.

4.4. Acknowledge function

- With the acknowledgment function, the enable current path is switched on again after a shutdown due to underspeed or overspeed.
- The acknowledgment takes place via the input Q.
- Automatic or manual acknowledgment is possible.
- With automatic acknowledgment, the Q input must always be connected to 24V DC.
- A manual acknowledgment takes place after a falling signal edge at the input Q ($t_Q \geq 200\text{ms}$ and $\leq 10\text{s}$).

- Signal that is longer than 10s does not cause a reset.
- For parameterization of the acknowledgment function see chapter " Configuration of the switching threshold and acknowledgement".

4.5. Functional diagram

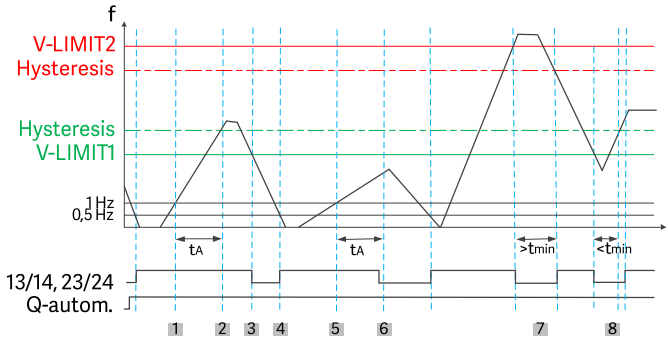
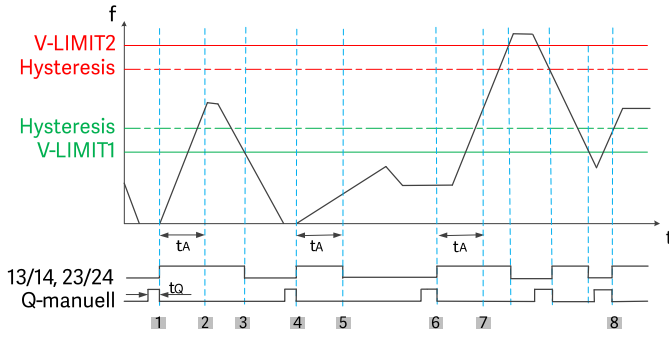
Automatic acknowledgement V-LIMIT 1 and V-LIMIT 2 (V-LIMIT 1 must be at least 1.1Hz!)		Manual acknowledgement V-LIMIT 1 and V-LIMIT 2	
			
1	Start-up monitoring time starts if $f > 1\text{Hz}$	1	Start-up monitoring time starts with the falling edge of the acknowledgement signal.
2	Start-up monitoring time is expired. Enabling current path remains closed because $f > \text{V-LIMIT 1}$.	2	Start-up monitoring time is expired. Enabling current path remains closed because $f > \text{V-LIMIT 1}$.
3	Enabling current path opens because $f < \text{V-LIMIT 1}$.	3	Enabling current path opens because $f < \text{V-LIMIT 1}$.
4	Enabling current path closes, if $f < 0,5\text{Hz}$.	4	Start-up monitoring time starts with the falling edge of the acknowledgement signal.
5	Start-up monitoring time starts if $f > 1\text{Hz}$.	5	Start-up monitoring time is expired. Enabling current path opens because $f < \text{V-LIMIT 1}$.
6	Start-up monitoring time is expired. Enabling current path opens because $f < \text{V-LIMIT 1}$.	6	Start-up monitoring time starts again.
7	The setpoint speed was reached outside of the minimum switch-off time. Enabling current path closes.	7	Start-up monitoring time is expired. Enabling current path remains closed.
8	The setpoint speed was reached within the minimum switch-off time. Enabling current path closes after 0.5s.	8	Enabling current path closes because $\text{V-LIMIT 1} < f < \text{V-LIMIT 2}$.

4.6. Schematic, operating element and display

L1, L2, L3	Measuring inputs
A1	Power supply +24V DC
A2	0V
Q	Acknowledgment input
O1, O2	Diagnostics outputs
13-14/23-24	Enabling contacts
SET	Configuration button
b1, b2, b4, b8	parameter 1-15
OK	Ready for operation
SPEED	Speed Status

4.7. Terminal description

- A1/ A2 Power supply 24V DC
- L1, L2, L3 Measuring inputs are to be connected directly to the motor, without switching contacts between.
- Q Acknowledgment input can be parameterized, manually or automatically
- 13/14, 23/24 Enabling contacts (2 NO-contacts). These switch off immediately if the parameterized speeds are undershot or exceeded or internal or external errors.
13/14, 23/24 are to be used in such a way that the intended safety function, e.g. emergency stop is executed.
- O1, O2 Digital positive switching semiconductor outputs for the transmission of switching states to a higher-level control for diagnostic tasks.

5 Applications

5.1. Motor with frequency converter

The operation on electric power drive systems with adjustable speed is possible. (Frequency converter)

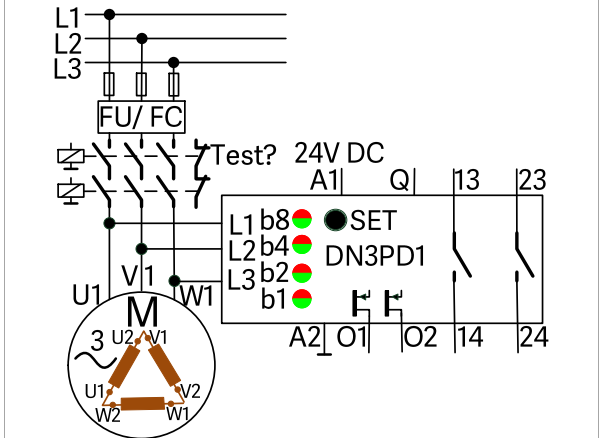

5.2. Motor with star-delta circuit

Operation on motors with star-delta connection or pole changeover is possible. For pole-changing motors, please note that DN3PD1 detects the frequency and not the speed! The measuring inputs L1 and L3 are bridged and directly connected to W1 on the motor. The measuring input L2 is directly connected to W2 on the motor.

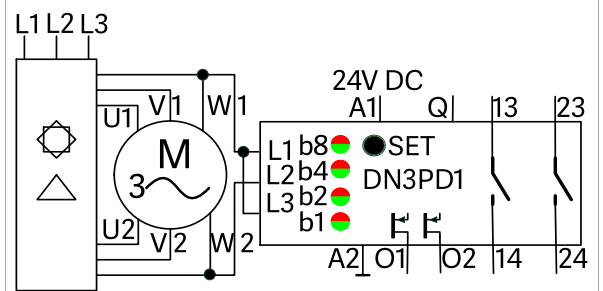

5.3. Single-phase motor

Operation on a single-phase motor is possible. The measuring inputs L1 and L3 are bridged and directly connected to U1 on the motor. The measuring input L2 is directly connected to U2 on the motor.

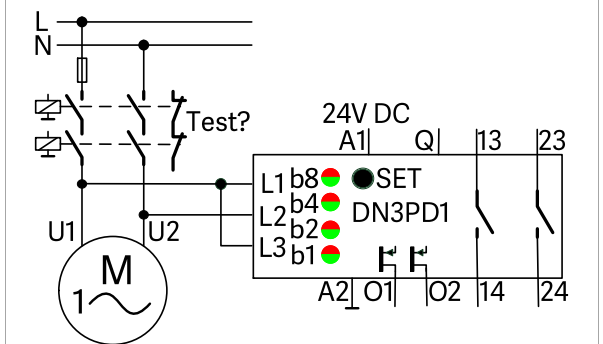

5.4. Synchronous motor

Applications with Synchronous motors are possible to a limited extent.



The following test must be carried out before using the DN3PD1:

When the motor is running with a motor frequency greater than the parameterized maximum frequency, terminal L2 on the module must be disconnected.

If the enabling current path closes in this case, the module is not suitable for use on this motor.

6 Mounting and removal

- Mounting on 35mm DIN rail according to EN 60715
- For the removal pull the lock device using a screwdriver
- Required distances according to DIN EN 50274, VDE 0660-514 must be observed
- No strong magnetic fields in the installation vicinity. (Magnetic fields < 30 A/m). These can interfere with the unit.

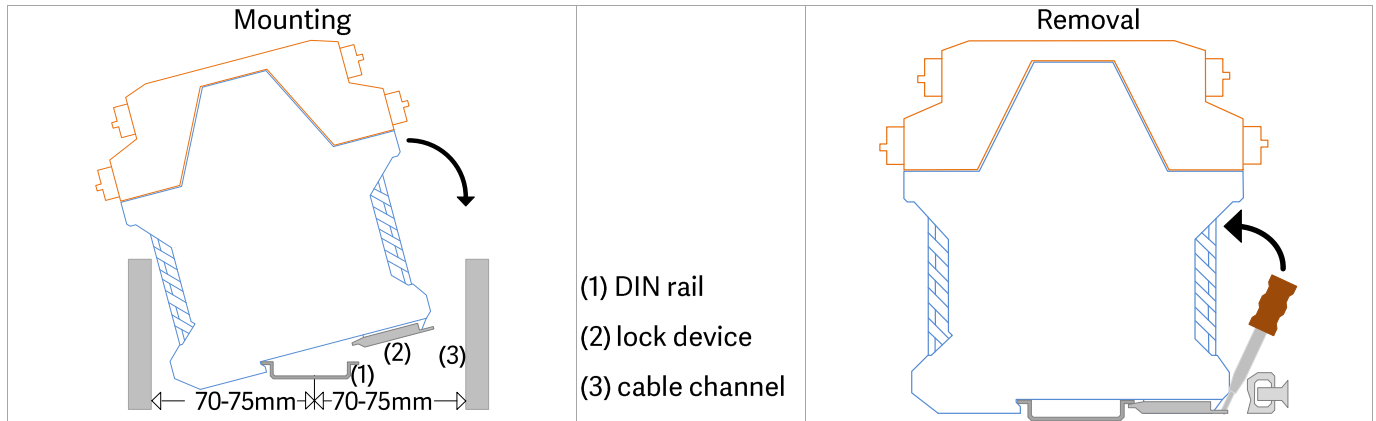

6.1. Wiring

- Conductor cross-section of 1.5 mm² must not be undercut.
- Use Copper wires approved up to 60°C/75°C.
- For of wire end sleeve is recommended.
- Loads connected to the measuring wires are not allowed.
- The placing of the measuring wires has to avoid a cross connection or short. Laying in cable channel.
- The regulations according to EN 60204-1 are to be followed.
- Use effective protective circuits parallel to an inductive load to avoid a shortcut of the output contacts.
- The arrangements of the overcurrent protective mechanism are to consider.
- Overvoltage > 32V DC destroys the unit.
- Use power supply with max. 32V output voltage also with fault..

6.2. Commissioning

- Switch off the unit before you start working.
- Wire the unit according to intended use
- Connect the power supply 24V DC to A1 and 0V to A2.
- Self-test follows. After faultless self-test the unit is in function. The LED OK is green

6.3. Example of application

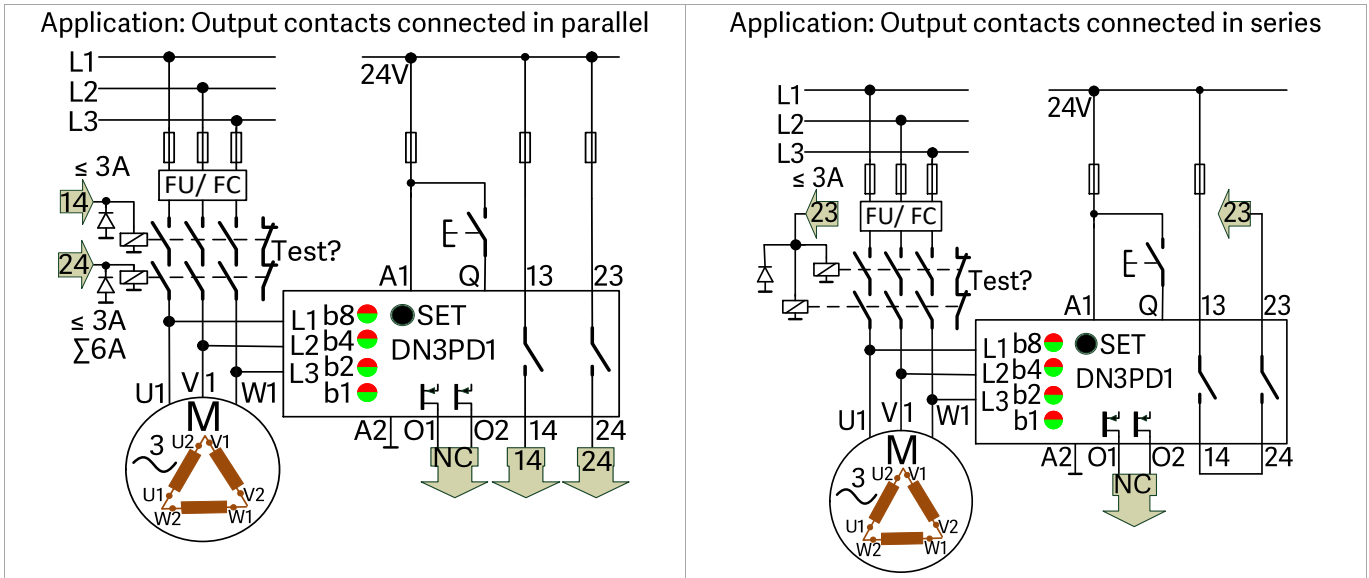

7 Parameterization of the switching thresholds

7.1. Important notes for parameterization

- Use a VDE-insulated screwdriver according to EN 60900 to press the SET button.
- The switching threshold and acknowledgement must be set correctly in order to ensure safe operation; this responsibility lies with the user.
- To determine the switching thresholds, the number of pole pairs must be taken into account:
- $f \text{ [Hz]} = (n \text{ [U/min]} / 60) \times \text{number of pole pairs}$
- Example: $5000 \text{ rev/min} \times 3 \text{ (number of pole pairs)} / 60 = 250\text{Hz}$
- During parameterization, the output contacts are switched-off.
- The parameters are not saved by voltage break or break of the parameterization for longer than 20s.
- Frequency of (V-LIMIT 2 -10%) must be higher than (V-LIMIT 1).
- On automatic acknowledgement must be $V\text{-LIMIT } 1 \geq 1,1\text{Hz}$.
- The monitoring of a minimum speed can be deselected. In this case, the lowest frequency for V-LIMIT 1 should be selected. There is no distance to keep to V-LIMIT 2. The output contacts remain closed at standstill.

7.2. Table of frequencies

These frequencies (in Hz) can be set as switching thresholds.

		Level x.1														
		1	2	3	4	5	6	7	8	9	10	11	12	13	14	15
Level x.2	1	0,15	1,26	1,96	3,05	4,8	7,4	11,5	18,0	28,00	43,6	68,0	104	159	255	396
	2	0,20	1,29	2,02	3,14	4,9	7,6	11,9	18,5	28,8	44,9	70,0	106	163	263	408
	3	0,30	1,33	2,08	3,24	5,04	7,9	12,2	19,1	29,70	46,3	72,1	109	167	270	418
	4	0,40	1,37	2,14	3,33	5,2	8,1	12,6	19,6	30,6	47,7	74,3	112	172	278	431
	5	0,50	1,41	2,20	3,43	5,35	8,3	13,0	20,2	31,5	49,1	76,5	116	178	287	443
	6	0,60	1,46	2,27	3,54	5,5	8,6	13,4	20,8	32,5	50,6	78,8	119	181	295	458
	7	0,70	1,50	2,34	3,64	5,7	8,8	13,8	21,5	33,4	52,1	81,1	123	187	304	471
	8	0,80	1,55	2,41	3,75	5,8	9,1	14,2	22,1	34,4	53,7	83,6	126	191	314	485
	9	0,90	1,59	2,48	3,86	6,0	9,4	14,6	22,8	35,5	55,3	86,1	130	196	323	500
	10	1,00	1,64	2,55	3,98	6,2	9,7	15,1	23,5	36,5	56,9	88,7	134	214	333	514
	11	1,05	1,69	2,63	4,10	6,4	10,0	15,5	24,2	37,6	58,6	91,3	138	221	342	529
	12	1,10	1,74	2,71	4,22	6,6	10,3	16,0	24,9	38,8	60,4	94,1	142	227	353	544
	13	1,15	1,79	2,79	4,35	6,8	10,6	16,5	25,6	39,9	62,2	97,5	147	234	363	560
	14	1,18	1,85	2,88	4,48	7,0	10,9	17,0	26,4	41,1	64,1	100	150	240	374	575
	15	1,22	1,90	2,96	4,61	7,2	11,2	17,5	27,2	42,0	66,0	102	155	247	385	594

7.3. Configuration of the switching threshold and acknowledgement

The current settings can be checked by briefly pressing the SET button. The LEDs show the parameters binary coded in five steps (Level). Two levels each determine V-LIMIT 1 and V-LIMIT 2 (see frequency table), the fifth level indicates the type of acknowledgement.

The permanent pressing of the SET button starts the parameterization mode and the levels can be run through. Releasing the button allows you to change this level parameter. The configuration can be adjusted by a short touch of the button. The new setting is saved again by pressing the button permanently. Each level can be recognized by its flashing rhythm or the LED color.

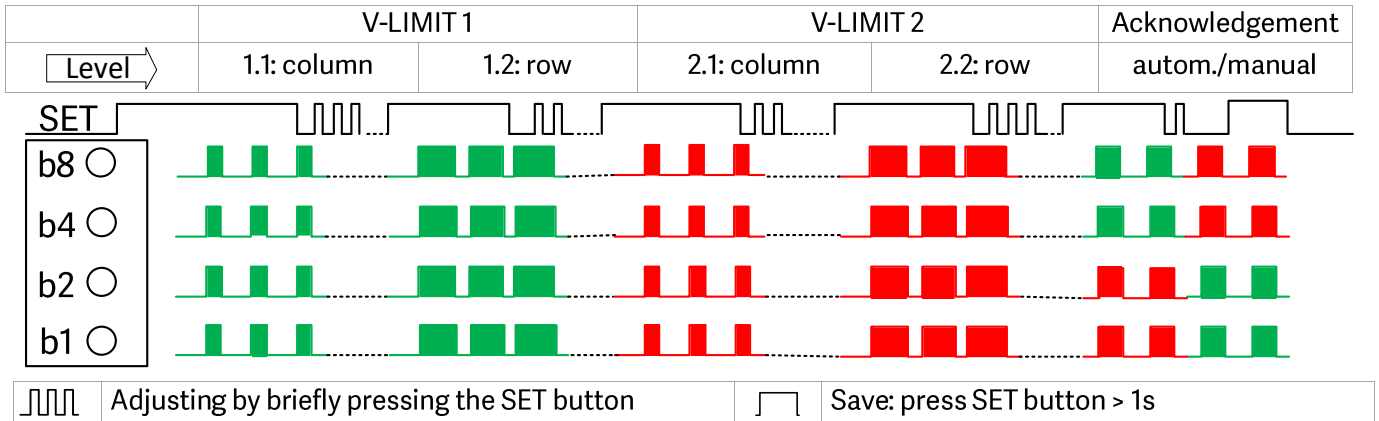

- Press SET button for >2s until all LED flash green.
- Adjust V-LIMIT 1, Level 1.1 binary coded by short key press (column of the table 7-1)
- Keep the SET button pressed: The value is saved and displayed as continuous light.
- Keep the SET button pressed until the blinking rhythm of all LEDs changes.
- Adjust V-LIMIT 1, Level 1.2 binary coded by short key press (row of the table 7-1).
- Keep the SET button pressed: The value is saved and displayed as continuous light.
- Keep the SET button pressed until the color of all LEDs changes.
- Adjust V-LIMIT 2, Level 1.1 binary coded by short key press (column of the table 7-1)
- Keep the SET button pressed: The value is saved and displayed as continuous light.
- Keep the SET button pressed until the blinking rhythm of all LEDs changes.
- Adjust V-LIMIT 2, Level 1.2 binary coded by short key press (row of the table 7-1).
- Keep the SET button pressed. The value is saved and displayed as continuous light.
- Keep the SET button pressed until the LED flash in pairs.
- Adjust the acknowledgement*) by short key press
- Keep the SET button pressed: The value is saved and displayed as continuous light.
- Release the button. The configuration is completed. The unit is ready for operation, if the OK LED shows green.

*) Adjust the acknowledgement

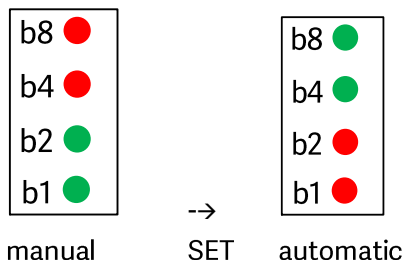

The set thresholds must be validated as follows:
Checking the set parameters in the display mode (short pressing of the SET key) and verification of the correct safety functions by checking the shutdown speeds, e.g. by comparison with the speed displayed on the frequency converter or use of other suitable speed measuring equipment.

7.4. Example for configuration

● V-LIMIT 1 = 1,0 Hz		● V-LIMIT 2 = 297,9 Hz		Acknowledgement
Level 1.1	Level 1.2	Level 2.1	Level 2.2	manual
column 1	row 10	column 14	row 6	
b8 ○ b4 ○ b2 ○ b1 ●	b8 ● b4 ○ b2 ● b1 ○	b8 ● b4 ● b2 ● b1 ○	b8 ○ b4 ● b2 ● b1 ○	b8 ● b4 ● b2 ● b1 ●

8 Diagnostics

The 2-color LEDs (b1, b2, b4, b8) indicate operational readiness, switching status, internal and external errors. The semiconductor output O1 is switched on when the frequency is within the parameterized range. See Fig. 8-1 The semiconductor output O2 indicates the operational readiness. This switches off in case of an error.

LED OK	LED SPEED	O1	O2	13/14, 23/24	Status	
green	green	24V	24V		acknowledged	in range
green	off	0V	24V		not acknowledged	out of range
green	flashing green	0V	24V		acknowledged	out of range
green	off	24V	24V		not acknowledged	in range
flashing red	off	0V	0V		error	see error report

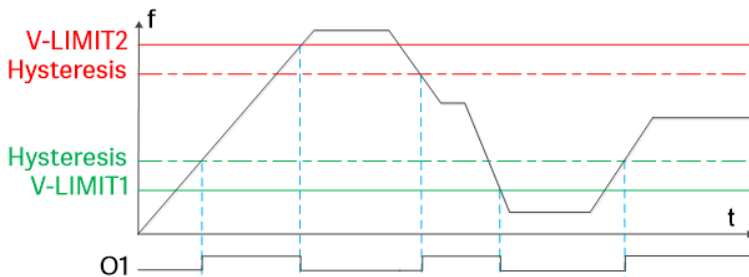
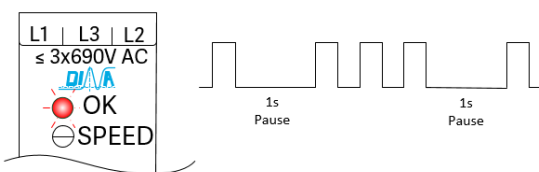

Fig. 8-1

8.1. Error report

The safety relay displays error messages using LED flashing codes. The blink code is repeated continuously with a break of 1 s. The meaning of the individual LED blink codes can be found in the table.

Example:
3 x flash / 1 s break / 3 x flash / 1 s break ...
That means error no. 3.



Flash-code	Possible cause	Remedy
1 x flash	incorrect power supply UB < 20V, > 32V	Check power supply UB = 20.5V-26,5V DC
2 x flash	(V-LIMIT 2) < (V-LIMIT 1)	(V-LIMIT 2 – 10%) > (V-LIMIT 1)!
3 x flash	incorrect acknowledge signal Q < 200ms oder > 10s	Check the wiring at input Q for cross or short circuits. For manual acknowledgment: Check whether the start signal is within the time range of min. 200ms to max. 10s.
4 x flash	open-circuit on L1, L2, L3	Check the wiring at the measuring inputs for <ul style="list-style-type: none"> • short circuit • cross-connection • wire break
5 x flash	single-channel measuring	Check the wiring at the measuring inputs for <ul style="list-style-type: none"> • short circuit • cross-connection • wire break
6 x flash	relay error	Send the device to DINA Elektronik for testing.
7 x flash	internal error	Send the device to DINA Elektronik for testing.
8 x flash	Measuring is different on master/slave	Send the device to DINA Elektronik for testing.
9 x flash	Frequency > 800Hz	check the frequency at the measuring inputs
10 x flash	Internal error	Send the device to DINA Elektronik for testing.

9 Technical data

9.1. Ambient conditions			
Ambient temperature (operation)	-20 to +55°C DIN IEC 60068-2-3		
Ambient temperature (storage)	-40 to +85°C DIN IEC 60068-2-3		
Maximum altitude	max. 2000m (above sea level)		
Vibration resistance 3 axis	Sinus 10–55Hz, 0,35mm, 10 cycles, 1 octave/min		
Air and creepage distances	DIN EN 50178, safe isolation		
Protection class	Installation in a closed cabinet, min. IP54		
9.2. Input data			
Operating voltage UB	24V DC -15 % / +10 %, reverse protection		
Current draw at 24V DC	typ. 80mA		
Current draw at L1, L2, L3	0,35mA at 690V AC		
Input voltage at L1, L2, L3	90 to 690V AC		
Input frequency at L1, L2, L3	≤ 600 Hz		
Switching hysteresis	10%		
Power consumption at A1/ A2	typ. 1,9W		
Status display	4 x LED 2-color		
Protection wiring	Overvoltage/ inverse polarity protection		
9.3. Output data			
Contact type	2 enabling NO-contacts		
Contact material	AgSnO ₂		
Operating voltage	24V DC / 230V AC		
Minimum switching current	3 mA/ 24V DC		
Maximum switching current	6A / 24V DC/ 230V AC		
Short-circuit strength	1000A SCPD 6A gL/gG		
Mechanical life	10 ⁷ switching cycles		
Switch-off time 01	Up to 30 Hz: 1 period (reciprocal value of the set frequency) + 10ms Over 30 Hz: 3 x 1 period + 10ms		
Switch-off time 02	Up to 2,5 Hz: 1 period (reciprocal value of the set frequency) + 10ms Over 2,5 Hz: 2 x 1 period + 10ms		
Output fuse	6 A gL/gG		
B10d values acc. to DIN EN 61810-2-1, 01.2012	AC15: 5A/230V AC, >2x10 ⁵ , AC1: 6A/230V AC, >2x10 ⁵	DC13: 4A/24V DC, >3x10 ⁵ DC1: 6A/ 24V DC, >7x10 ⁵ switching cycles	
Total current 13-14 and 23-24	with parallel connection: 6A		with serial connection: 3A
Outputs O1, O2	≤ 100mA(UB-1V) shot-circuit and overload protection		
9.4. General data			
Nominal operating mode	100 %		
Protection class	IP20		
Mounting position	vertical or horizontal		
Housing material/ Type	Polyamide PA not increased/ ME/ Phoenix Contact		
Dimensions	B x H x T/ 22,5 x 114 x 111 mm		
Degree of pollution	2		
Overvoltage category	III		
9.5. Connection data			
Terminals/ Material	Push-in, pluggable/ PA		Screw, pluggable/ PA
Number of pins	4	5	3
Rated surge voltage	4kV	2,5kV	8kV
Rated insulation voltage	320V	160V	1000V
Conductor cross-section, flexible with wire end sleeve	0,25 - 2,5mm ²	0,25 - 1,5mm ²	0,25 - 2,5mm ²
Conductor cross section AWG	24...12	24...16	24...12
Connection wire	60/75°C Copper		
Tightening torque min/max	-	-	0,5Nm/0,6Nm

9.6. Relay load curve

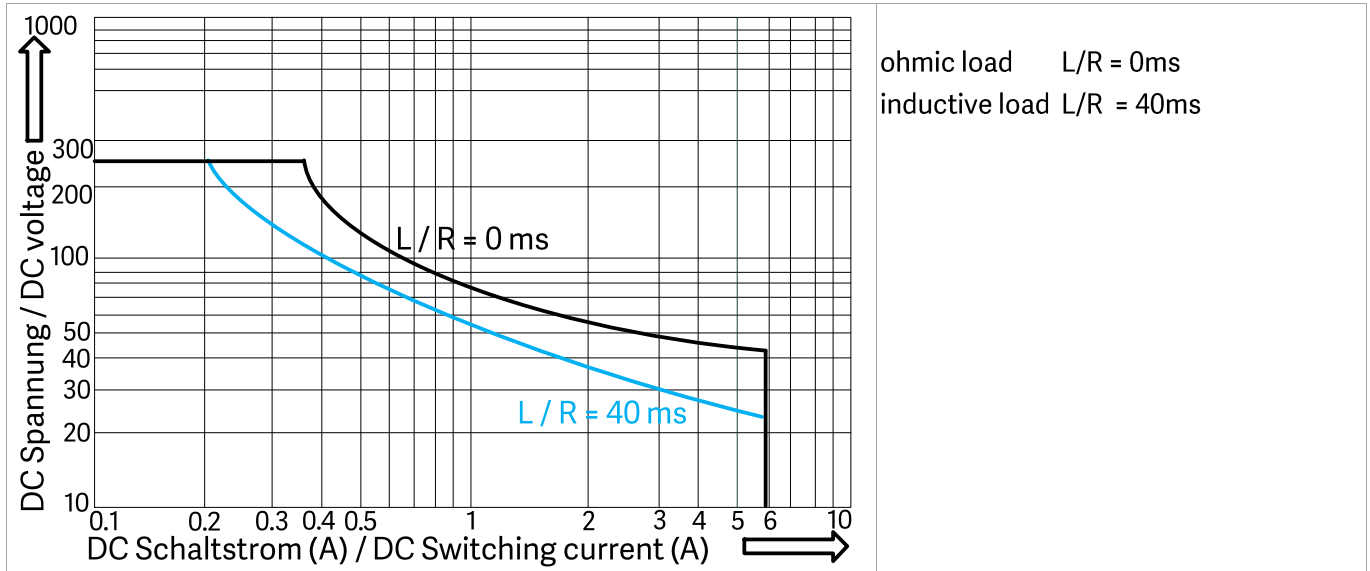

WARNING
Loads with high capacitive component can destroy the output contacts because the switching current is very high.

10 Dimensions

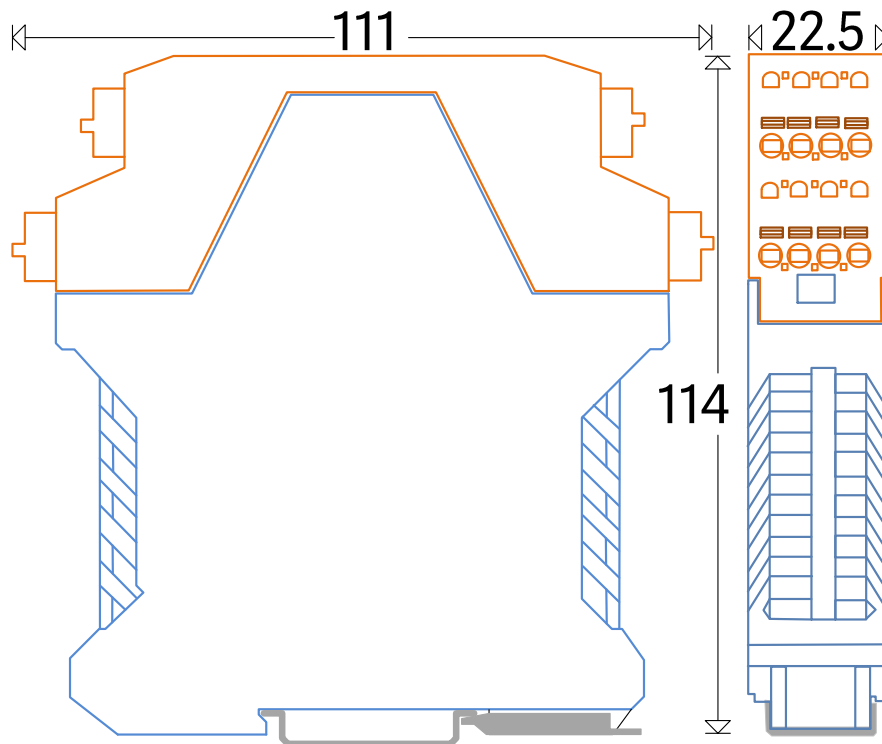



DINA Elektronik GmbH
Esslinger Str. 84
D72649 Wolfschlügen
Phone +49 7022 95170
Fax +49 7022 9517700
info@dina.de
www.dina.de
